

# Chromalox®

## Installation, Operation and MAINTENANCE

### SERVICE REFERENCE

DIVISION 4	SECTION HVH
SALES REFERENCE (Supersedes PF203-5)	PF203-6
161-305679-001	
DATE	JANUARY, 2012

## Type HVH Horizontal/Vertical Unit Heater



### GENERAL

#### Heater Location Instructions:

Arrange units so their discharge air streams:

- Are subjected to a minimum of interference from columns, machinery and partitions.
- Wipe exposed walls without blowing directly at them.
- Are directed away from room occupants in comfort heating.
- Are directed along the windward side when installed in a building exposed to a prevailing wind.
- See additional mounting limitations in Table D.

Locate thermostat on interior partition walls or posts away from cold drafts, internal heat sources and away from heater discharge air streams.

Small rooms can be heated by one unit heater. Where two walls are exposed, the heater should be mounted as shown in Figure 1.

Large rooms require multi-unit installation. Number and capacity of units will be determined by volume of building and square feet of floor area to be heated. Arrange units to provide perimeter air circulation where each unit supports the air stream from another.

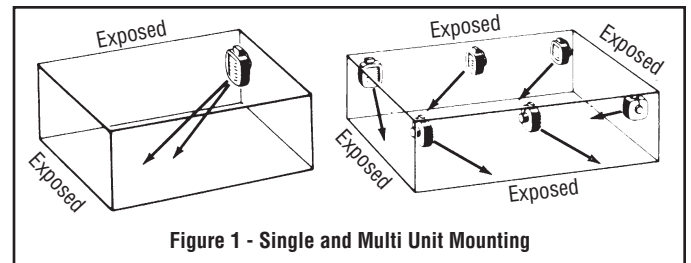

Figure 1 - Single and Multi Unit Mounting

### WARNING

Failure to understand and follow these installation instructions and the "WARNING" notes therein may result in serious personal injury from electrical shock, or from the heater falling due to faulty installation.

#### ⚠ WARNING

**This heater is not intended for use in hazardous atmospheres where flammable vapors, gases, liquids or other combustible atmospheres are present as defined in the National Electric Code. Failure to comply can result in explosion or fire. For these applications see PDS CXH-A-EP (PF490).**

#### ⚠ WARNING

**ELECTRIC SHOCK HAZARD. Disconnect all power before installing or servicing heater. Failure to do so could result in personal injury or property damage. Heater must be installed or serviced by a qualified person in accordance with the National Electrical Code, NFPA 70.**

#### ⚠ WARNING

**This heater is not intended for use in exposed outdoor, marine, or wash-down environments or in areas where corrosive liquids or fumes exist under normal conditions.**

#### ⚠ WARNING

**ELECTRIC SHOCK HAZARD. Any installation involving electric heaters must be performed by a qualified person and must be effectively grounded in accordance with the National Electrical Code to eliminate shock hazard.**

Do not mount mercury type thermostat directly on unit. Vibration could cause heater to malfunction.

The heater must be mounted at least 7' above the floor to prevent accidental contact with the heating elements or fan blade which could cause injury.

Keep at least 5' clearance in front of the heater. Refer to Table D for side, top and back clearance requirements.

## WARNING (cont'd.)

The ceiling mounting structure and the anchoring provisions must be of sufficient strength to support the combined weight of the heater and mounting bracket. (Refer to Table B for weights of heater and bracket.)

The wall or mounting surface, and the anchoring provisions must be capable of supporting the combined weight of the heater and mounting brackets cantilevered from the mounting surface. (Refer to Table B for weights of heater and brackets and for cantilevered force expressed in foot-pounds.)

Fan blade rotation must be checked. If airflow is not moving out through the louvers, interchange any two of the three customer power leads on three-phase units only.

**Table B – Weights of Heater & Bracket**

Model	WEIGHT (Lbs.) Heater and Brackets		
	Ceiling Weight	Wall	
		Weight	Ft.-Lbs.
HVH-02 to HVH-05	27	25-1/2	48
HVH-15 to HVH-20	55	67-1/4	112
HVH-25, 30, 35	108	105	126.3
HVH-40, 45, 50	118	115	138.4

**Specifications – Table A**

Model	Volts	Watts	Phase	Amps	BTU	A Height	B Width	C Depth	Std. Contactor Rating (Qty.)	Wiring Dia. Figure
HVH-02-81	208	2,667	1	12.8	8,850	16-1/8	13	10	—	10
HVH-02-21	208/240	2000/2,667	1	11.1*	8,850	16-1/8	13	10	—	10
HVH-02-71	277	2,667	1	9.6	8,850	16-1/8	13	10	—	10
HVH-04-81†	208	4,000	1	19.2	13,661	16-1/8	13	10	—	10
HVH-04-83†	208	4,000	3	11.2	13,661	16-1/8	13	10	30A (1)	12
HVH-04-21†	208/240	3,000/4,000	1	16.7*	13,661	16-1/8	13	10	—	10
HVH-04-23†	208/240	3,000/4,000	3	9.6*	13,661	16-1/8	13	10	30A (1)	12
HVH-04-71	277	4,000	1	14.5	13,661	16-1/8	13	10	—	10
HVH-04-43	480	4,000	3	4.8	13,661	16-1/8	13	10	30A (1)	11
HVH-05-81†	208	5,000	1	24.0	17,076	16-1/8	13	10	—	10
HVH-05-83†	208	5,000	3	13.8	17,076	16-1/8	13	10	30A (1)	12
HVH-05-21†	208/240	3,750/5,000	1	20.8*	17,076	16-1/8	13	10	—	10
HVH-05-23†	208/240	3,750/5,000	3	12.1*	17,076	16-1/8	13	10	30A (1)	12
HVH-05-71	277	5,000	1	18.2	17,076	16-1/8	13	10	—	10
HVH-05-43	480	5,000	3	6.0	17,076	16-1/8	13	10	30A (1)	13
HVH-07-81†	208	7,500	1	36.1	25,598	20-5/8	17-1/8	12-3/4	50A (1)	12
HVH-07-83	208	7,500	3	20.9	25,598	20-5/8	17-1/8	12-3/4	30A (1)	12
HVH-07-21†	208/240	5,625/7,500	1	31.1*	25,598	20-5/8	17-1/8	12-3/4	30A (1)	12
HVH-07-23	208/240	5,625/7,500	3	18.1*	25,598	20-5/8	17-1/8	12-3/4	30A (1)	12
HVH-07-71	277	7,500	1	27.2	25,598	20-5/8	17-1/8	12-3/4	30A (1)	12
HVH-07-43	480	7,500	3	9.0	25,598	20-5/8	17-1/8	12-3/4	30A (1)	13
HVH-10-81†	208	10,000	1	48.0	34,130	20-5/8	17-1/8	12-3/4	50A (1)	12
HVH-10-83	208	10,000	3	27.8	34,130	20-5/8	17-1/8	12-3/4	30A (1)	12
HVH-10-21†	208/240	7,500/10,000	1	41.7*	34,130	20-5/8	17-1/8	12-3/4	30A (1)	12
HVH-10-23	208/240	7,500/10,000	3	24.0*	34,130	20-5/8	17-1/8	12-3/4	30A (1)	12
HVH-10-43	480	10,000	3	12.0	34,130	20-5/8	17-1/8	12-3/4	30A (1)	13
HVH-12-83	208	12,500	3	34.8	42,663	20-5/8	17-1/8	12-3/4	50A (1)	12
HVH-12-23	208/240	9,375/12,500	3	30.1*	42,663	20-5/8	17-1/8	12-3/4	50A (1)	12
HVH-12-43	480	12,500	3	15.1	42,663	20-5/8	17-1/8	12-3/4	30A (1)	13
HVH-15-83	208	15,000	3	41.8	51,195	20-5/8	17-1/8	12-3/4	50A (1)	12
HVH-15-23	208/240	11,250/13,000	3	36.2*	51,195	20-5/8	17-1/8	12-3/4	50A (1)	12
HVH-15-43	480	15,000	3	18.1	51,195	20-5/8	17-1/8	12-3/4	30A (1)	13
HVH-20-23	208/240	14,758/19,500	3	47.0	66,534	20-5/8	17-1/8	14-1/16	50A (2)	15
HVH-20-43	480	19,500	3	23.5	66,534	20-5/8	17-1/8	14-1/16	50A (1)	14
HVH-20-63	600	19,500	3	18.8	66,534	20-5/8	17-1/8	14-1/16	50A (1)	14
HVH-25-23	208/240	18,720/24,900	3	60.0	84,959	29-3/16	26-1/16	14-5/8	50A (2)	15
HVH-25-43	480	25,000	3	30.2	85,300	29-3/16	26-1/16	14-5/8	50A (1)	14
HVH-25-63	600	25,000	3	24.1	85,300	29-3/16	26-1/16	14-5/8	50A (1)	14
HVH-30-23	208/240	22,400/29,900	3	72.1	102,019	29-3/16	26-1/16	14-5/8	50A (2)	15
HVH-30-43	480	30,000	3	36.2	102,360	29-3/16	26-1/16	14-5/8	50A (1)	14
HVH-30-63	600	30,000	3	29	102,360	29-3/16	26-1/16	14-5/8	50A (1)	14
HVH-35-23	208/240	25,600/34,000	3	81.9	116,008	29-3/16	26-1/16	14-5/8	50A (3)	15
HVH-35-43	480	34,000	3	41	116,008	29-3/16	26-1/16	14-5/8	50A (1)	14
HVH-35-63	600	34,200	3	33	116,690	29-3/16	26-1/16	14-5/8	50A (1)	14
HVH-40-23	208/240	28,000/37,400	3	90.1	127,609	29-3/16	26-1/16	14-5/8	50A (3)	16
HVH-40-43	480	37,400	3	45.1	127,609	29-3/16	26-1/16	14-5/8	50A (1)	14
HVH-40-63	600	37,500	3	36.2	127,950	29-3/16	26-1/16	14-5/8	50A (1)	14
HVH-45-23	208/240	33,700/44,800	3	107.9	152,858	29-3/16	26-1/16	14-5/8	50A (3)	16
HVH-45-43	480	44,800	3	54	152,858	29-3/16	26-1/16	14-5/8	50A (2)	15
HVH-45-63	600	45,200	3	43.6	154,222	29-3/16	26-1/16	14-5/8	50A (1)	14
HVH-50-23	208/240	38,400/50,000	3	123.1	174,353	29-3/16	26-1/16	14-5/8	50A (3)	16
HVH-50-43	480	50,000	3	61.6	174,353	29-3/16	26-1/16	14-5/8	50A (2)	15
HVH-50-63	600	50,000	3	49.5	175,036	29-3/16	26-1/16	14-5/8	50A (2)	15

\* Note: 208V amperage is 86% of 240V value.

† These models can be field changed from single phase to three phase or three phase to single phase.

# INSTALLATION

**NOTICE** – These heaters are designed for wall and ceiling mount. Other modes of mounting void factory warranty.

## Vertical Air Flow

1. Height above floor
  - A. It is recommended that the heater only be used with ceiling heights of 12 feet or greater. Minimum spacing to ceiling is 6 inches, use 3/8-18" thread stock (supplied by others) as shown in Figure 3.
  - B. Minimum mounting height is 10 feet from floor to bottom of heater.
2. Spacing to walls.
  - A. Side of case to wall 6". Top or bottom of case to back wall is 10-1/4" (HVH-02 to HVH-05), 13" (HVH-15 to HVH-20) and 15-1/2" (HVH-25 to HVH-50).

## CEILING (Vertical Airflow):

- A. The heater can be rod mounted to the ceiling by installing four (4) threaded mounting rods in the threaded holes located on the top of the heater as shown in Figure 3. (Refer to Table C for mounting rod thread size.)
- B. Securely attach the four (4) mounting rods to the ceiling. (Refer to Table D for wall and ceiling clearances, and Figure 2 for mounting spacing specifications.)

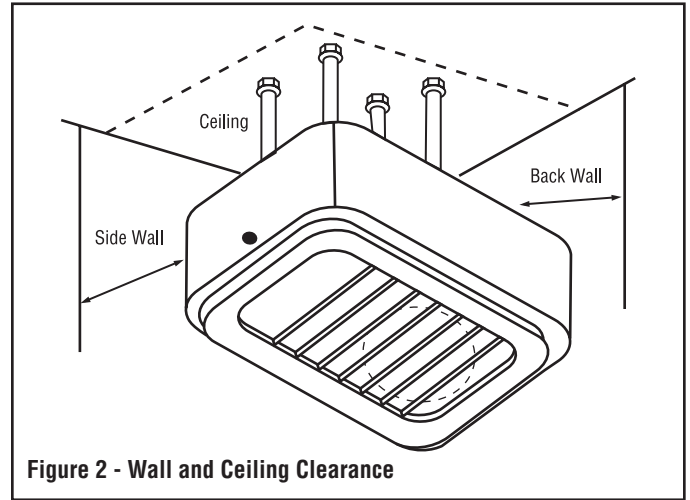

**Figure 2 - Wall and Ceiling Clearance**

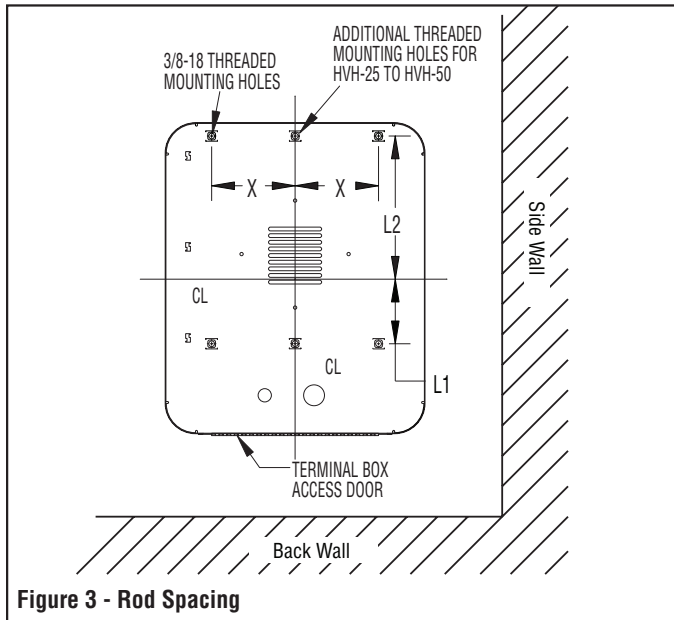

**Figure 3 - Rod Spacing**

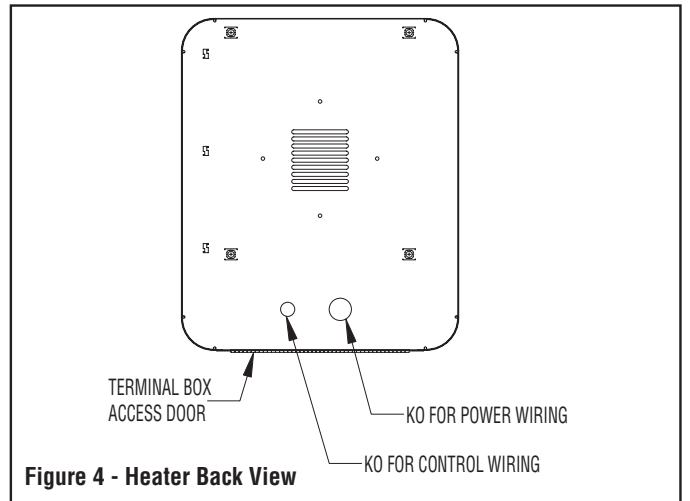

**Figure 4 - Heater Back View**

Knockout Sizes		
HVH-02 - 05	1/2"	3/4" (1)
HVH-07 - 20	1/2"	1" (1)
HVH-25 - 50	1-1/4"	2" (1)

**Table C** — Rod Thread Type and Spacing Dimensions (inches) for Vertical Discharge.

Unit	Rod Thread Type	Dimensions – (In.)		
		L1	L2	X
2-5 kW	3/8-16	2-7/8	7-1/8	3-3/4
7-1/2 - 20 kW	3/8-16	4-5/16	9-3/8	5-1/2
25 - 50 kW	3/8-16	8-15/16	14	9-15/16

**Table D** — Clearance Requirements (Vertical Discharge)

Model	Mounting Limitations (In.)		
	Back to Wall	Side to Wall	Top to Ceiling
HVH-02 Thru HVH-05	10-1/4	6	6
HVH-07 Thru HVH-20	13	6	6
HVH-25 Thru HVH-50	15-1/2	6	6

## Horizontal Air Flow

1. Height above floor
  - A. In areas where ceiling height is more that 12 feet, recommended mounting height is approximately 10 feet to underside of heater.

- B. For ceiling heights of 12 feet or less, maximum mounting height is determined by the use of the mounting bracket offered for these heaters. Minimum spacing to ceiling is 7-3/4". (See Figure 5)

- C. In either case, the minimum mounting height is 7 feet from floor to bottom of heater.

2. Spacing to adjacent walls.
  - A. Rear of case to back wall 2" minimum.
  - B. Side of case to side wall 6" minimum.

## CEILING – Horizontal Airflow (See Figure 5):

The ceiling mounting bracket is fastened to the top of the heater using the four (4) bolts supplied with the mounting bracket. The bracket is then mounted to the ceiling using a 5/8" bolt (by others).

## WALL – Horizontal Airflow (See Figure 6):

Wall mounting necessitates the use of both an adaptor mounting bracket and a wall mounting bracket. First, attach the ceiling mounting bracket to the heater. Then, attach the wall mounting bracket to the wall using four 5/16" bolts and six 3/8" bolts (by others). Attach the ceiling mounting bracket on the heater to the wall mounting bracket using the 5/8" bolt provided.

## INSTALLATION (cont'd.)

The heater may be rotated to discharge in the desired direction. Open and adjust louvers to desired position. See Figure 5 and 6 for additional mounting details.

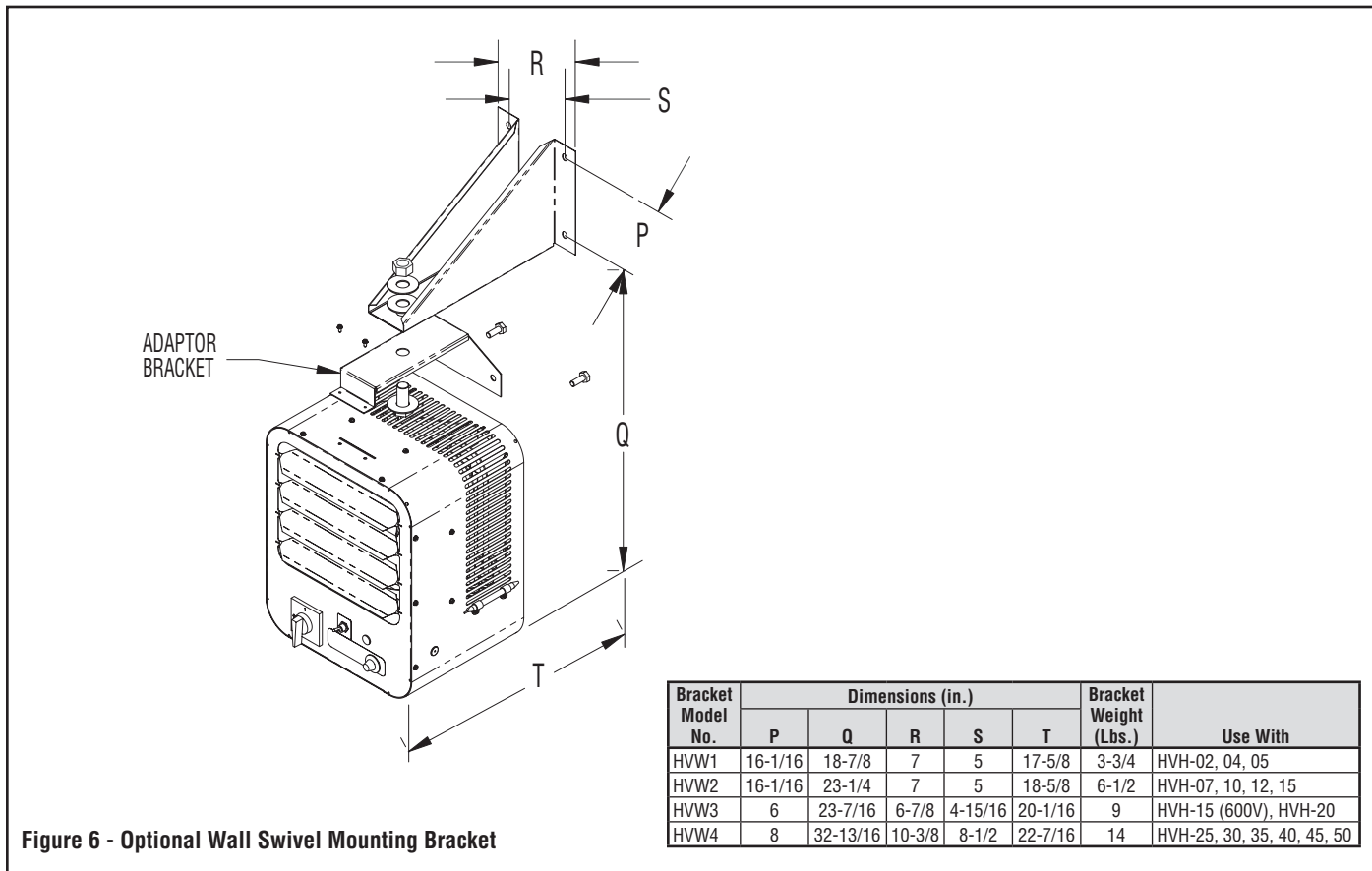
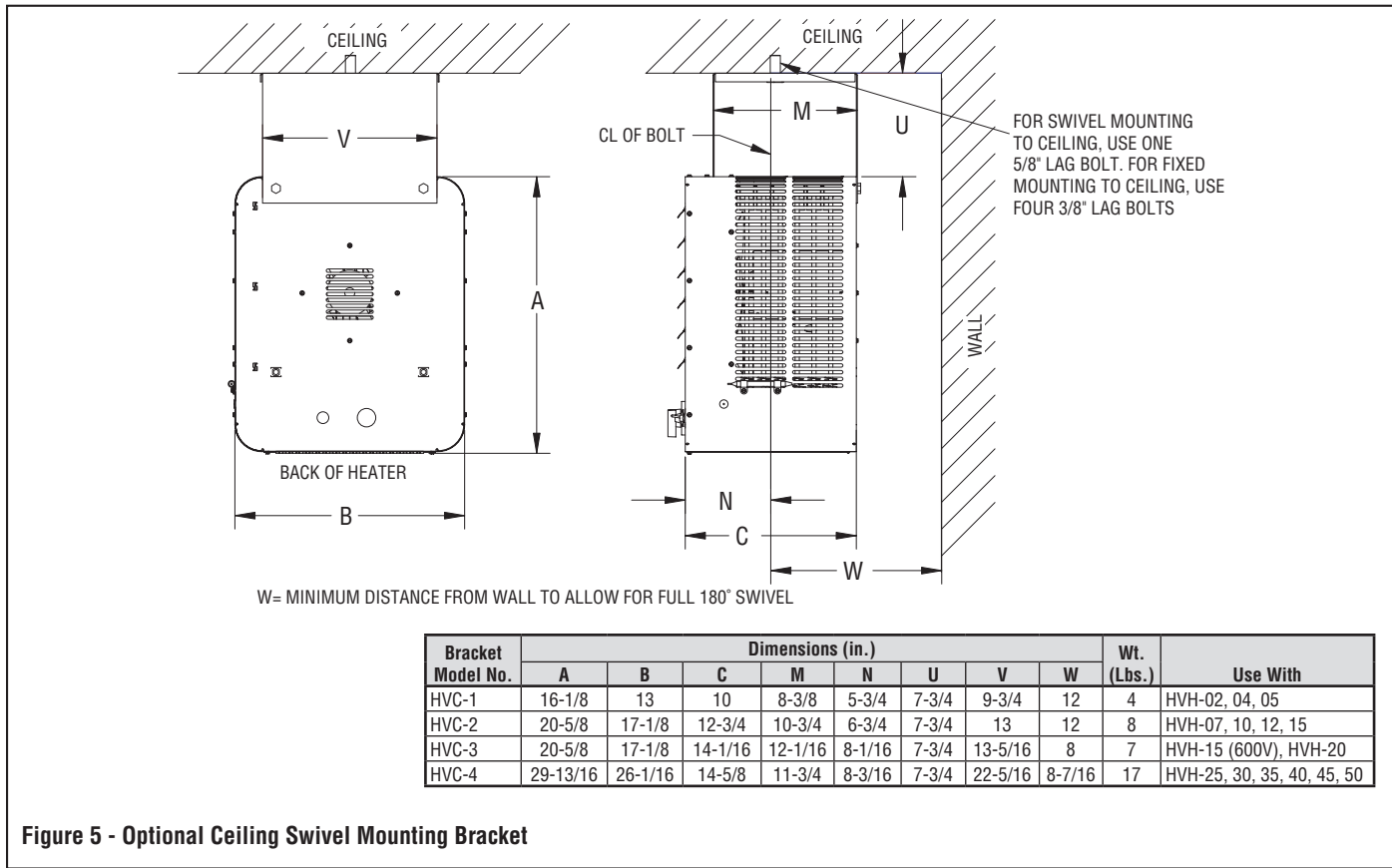

## WIRING

### ⚠ WARNING

**ELECTRIC SHOCK HAZARD. Be sure electricity is turned off at main switch first before wiring. Any installation involving electric heaters must be effectively grounded in accordance with the National Electrical Code to eliminate shock hazard.**

1. Use heater only on the voltage and frequency specified on the nameplate.
2. All wiring should be done in accordance with local codes and the National Electrical Code by a qualified person as defined in the NEC.
3. Two knockouts are provided on the back of the heater for wire entry. See Figure 4 for location of knockouts.
4. Branch circuit wire for connection to heater must be at least 60°C wire.
5. The bottom access door is hinged. There are two screws that must be removed to gain access (Figure 3).
6. A ground wire or ground lug is provided near the power connection point (ground Wire on HVH-02 to HVH-20 and ground lug on HVH-25 to HVH-50).
7. Terminals on contactor or on line voltage terminal block are supplied to be connected to accept the correct size power supply wire. Copper rated at 600V and 60°C is satisfactory for the heater branch circuit.
8. Electrical accessories, either kits or factory-installed options, are shown connected by a dash line on the heater wiring diagram.
9. Wiring connections are to be made on designated wire leads as shown in the wiring diagrams located inside the access door.
10. Louver adjustment (**Do not attempt to adjust while heater is operational**): Louvers have been preset at factory with the minimum open angle. Decreasing the 45° angle may result in high temperatures and functioning of the over temperature control. To increase the opening angle, grasp the left end of louver with the left hand using the index finger and thumb. Grasp right end of louver with right hand in the same manner. Twist louver to the desired position.

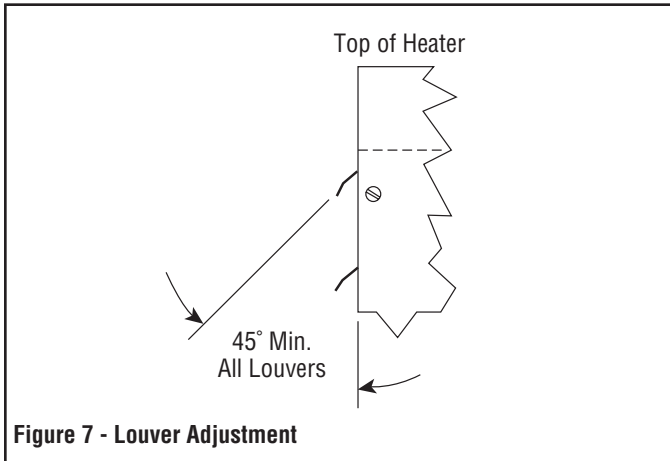

**Figure 7 - Louver Adjustment**

### POWER DISCONNECT SWITCH

(Available as a kit or factory installed option). This switch disconnects the power to the power leads when the handle is turned to its off position. Refer to Instruction Sheet PF207.

1. Use copper conductor supply wire only when connecting to the power line. (See Figure 8.)
2. Connection to the switch pigtails should be made with compression connectors and the joint should be then well insulated.
3. Consult the local wiring code in your area.

### SUMMER FAN SWITCH - Refer to Instruction sheet PF205 without relay, PF206 with relay.

(MOUNTED ON FRONT OF HEATER). When the switch handle is pointing toward the Summer (Fan ON) position, the fan will run continuously. When the switch handle is pointing toward the WINTER (HEAT) position, the fan will run only when the heating elements are hot.

### REMOTE SUMMER FAN SWITCH

(MANUAL SWITCH-LINE VOLTAGE). The wall switch is packed in the wiring compartment. The remote fan switch is mounted external and remote from the HVH unit heater. The voltage of the remote fan switch is the same as the supply voltage to the HVH heater.

1. Use 14 gauge copper, NEC Class 1, 600V rated insulated wire. Wiring must meet all Local and NEC requirements for 480-volt service.
2. Install the remote fan switch in standard wall box in any convenient location that is protected from traffic or other accidental damage.
3. Connect the 14 gauge copper field wire to the switch lead wires with suitable connectors.

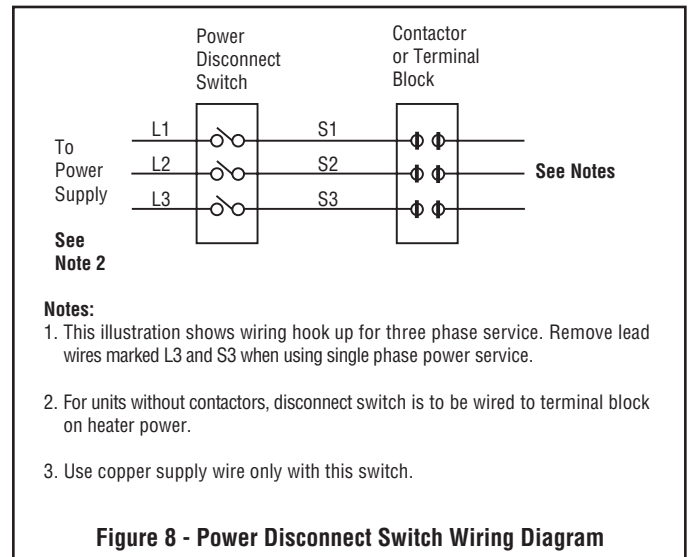

**Figure 8 - Power Disconnect Switch Wiring Diagram**

### REMOTE FAN SWITCH

480V + Heaters require an additional fan relay. (Available as a kit or factory installed option and standard on heaters 20kW and above). The wall switch is packed in the wiring compartment.

1. Use 18 gauge (min.) NEC Class 1, 600V wiring that meets all Local and NEC requirements.
2. Install the wall switch in a standard wall box in any convenient location that is protected from traffic or other accidental damage.
3. Connect the field wire to the switch lead wires with suitable connectors.

### OPTIONAL THERMOSTAT (HVH-TK) Refer to Instruction Sheet PF204.

Heaters can be equipped with an optional thermostat of the Bulb and Capillary type for automatic temperature control (Figure 8). The thermostat controls the heating elements and fan simultaneously to achieve set temperature.

The “Lo” setting of the thermostat is approximately 40°F, and the “Hi” setting is approximately 90°F.

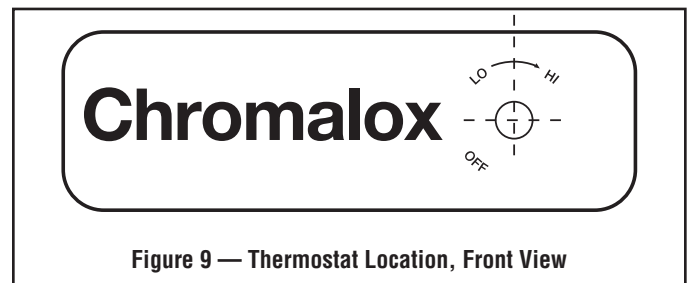

**Figure 9 — Thermostat Location, Front View**



## WIRING (cont'd.)

### CONTROL VOLTAGE WIRING — EXTERNAL REMOTE THERMOSTATS AND FAN SWITCHES

#### ⚠ WARNING

**ELECTRIC SHOCK HAZARD. Be sure electricity is turned off at main switch first before wiring. Any installation involving electric heaters must be effectively grounded in accordance with the National Electrical Code to eliminate shock hazard.**

1. Use 600 volt, NEC Class 1 insulated wiring with a minimum gage

of 18 for thermostats and minimum gauge of 14 for line voltage motor switch (remote fan switch without relay).

2. The thermostat should be located in the area to be heated on an inside wall. The thermostat should not be exposed to drafts, sunlight, radiation from hot objects, or in a direct line with the discharge from the unit heater.
3. Install the thermostat approximately 5 feet above the floor line.
4. Install the remote fan switch in any convenient location that is protected from traffic or likely accidental damage.
5. Internal optional controls are shown on the unit heater wiring diagrams by a dash line.

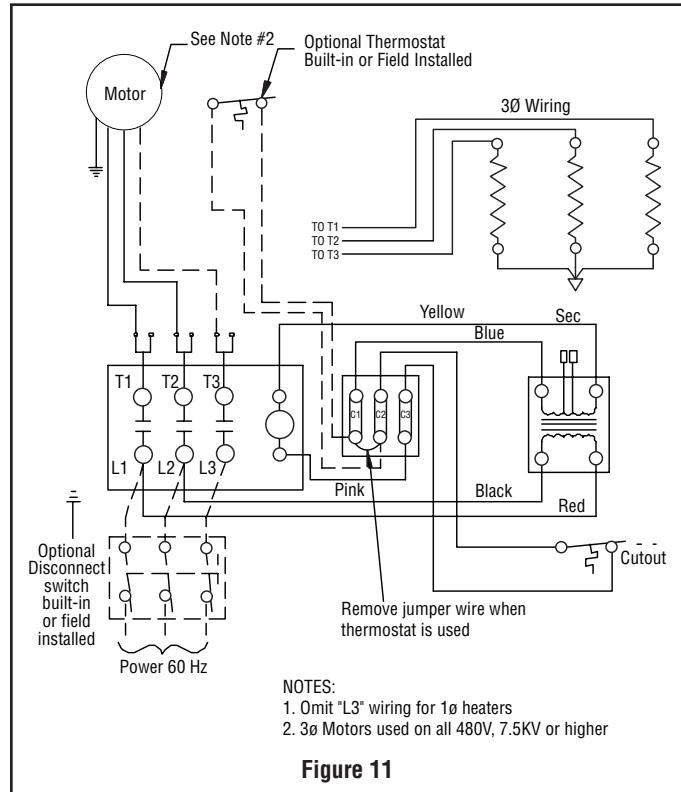
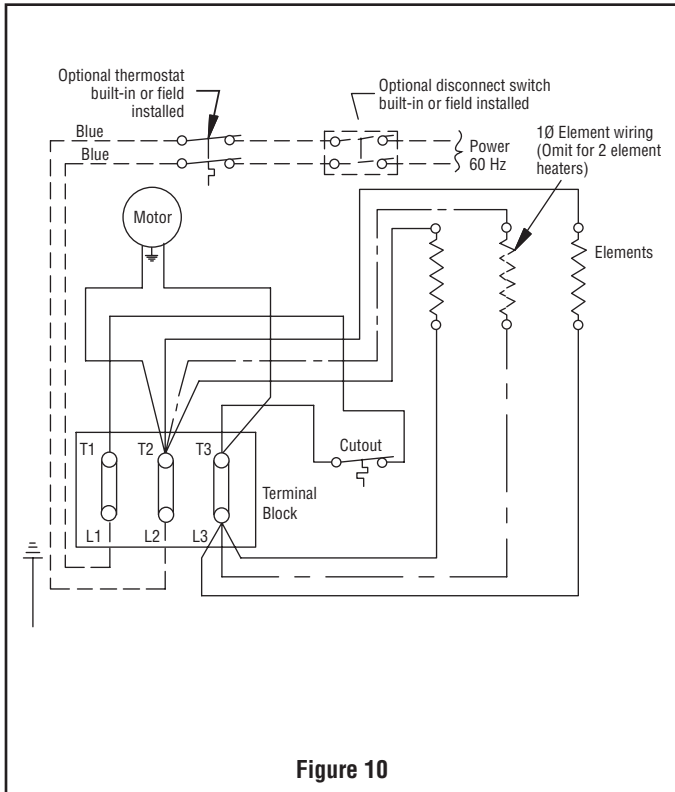

**NOTES:**  
 1. Omit "L3" wiring for 1Ø heaters  
 2. 3Ø Motors used on all 480V, 7.5KV or higher

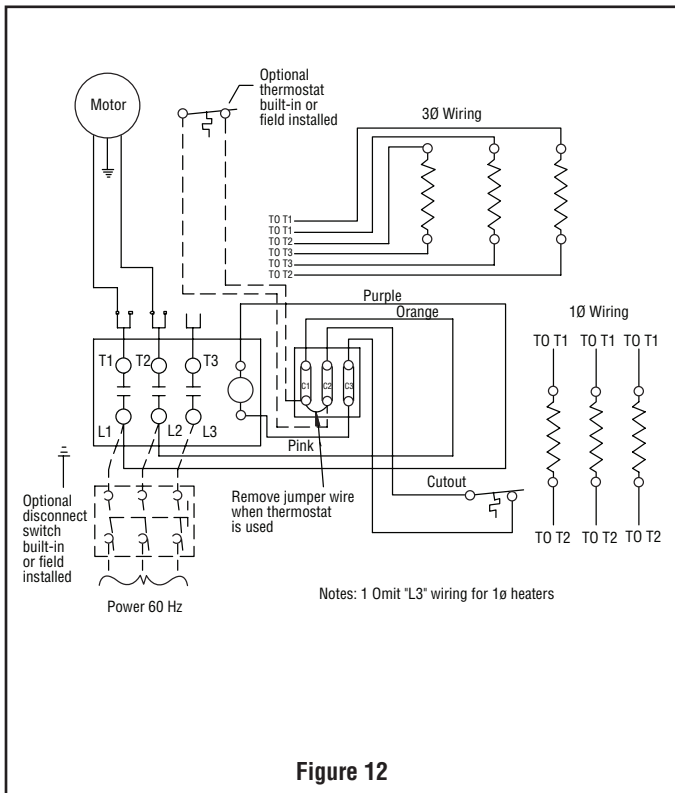

Notes: 1 Omit "L3" wiring for 1Ø heaters

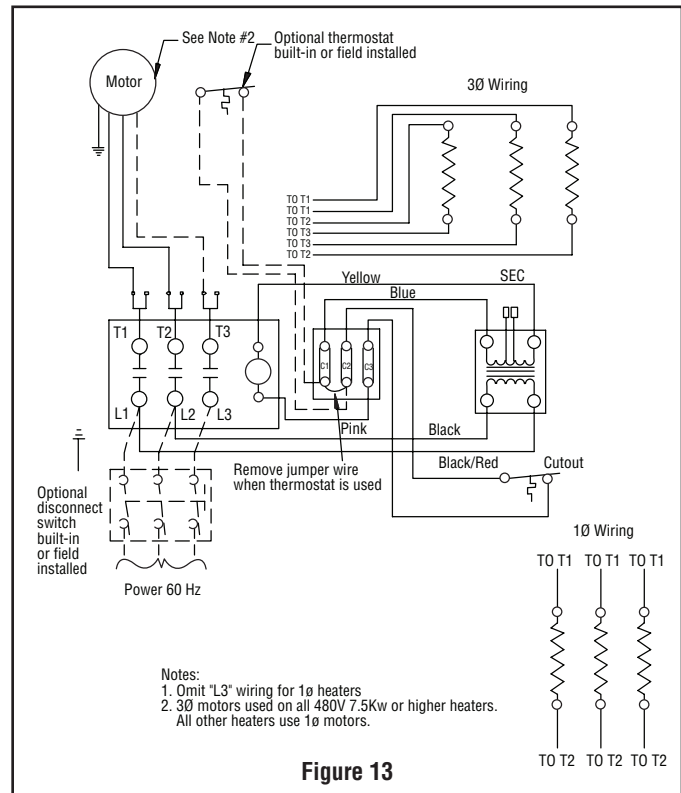

**Notes:**  
 1. Omit "L3" wiring for 1Ø heaters  
 2. 3Ø motors used on all 480V 7.5Kw or higher heaters.  
 All other heaters use 1Ø motors.

# WIRING (cont'd.)

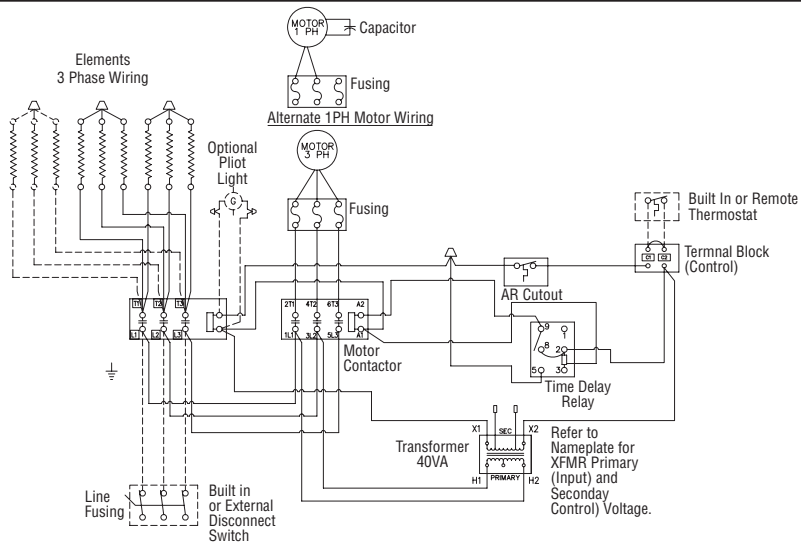

Figure 14

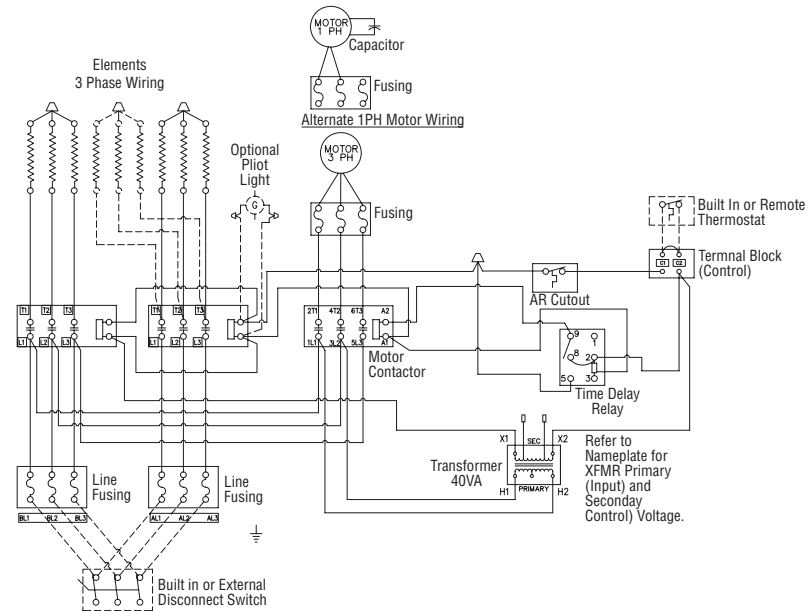

Figure 15

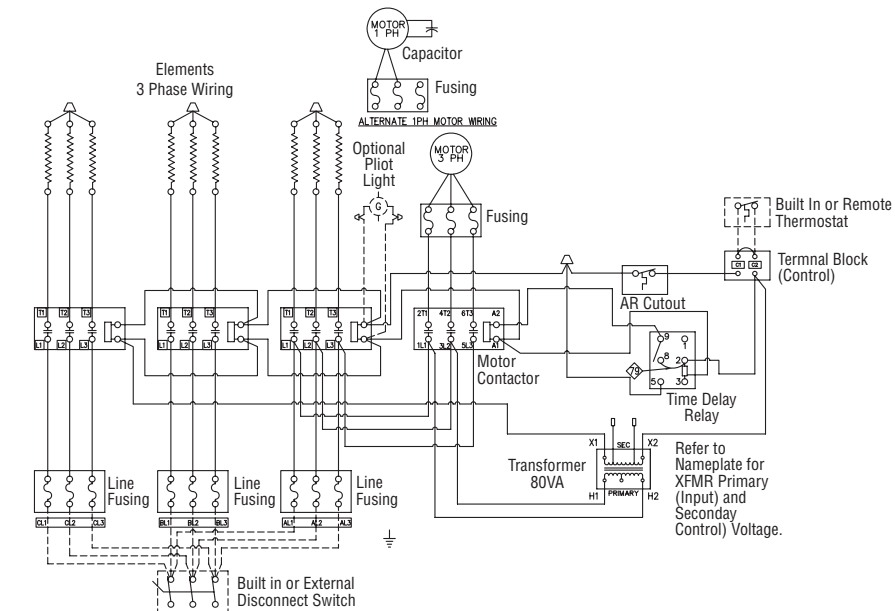
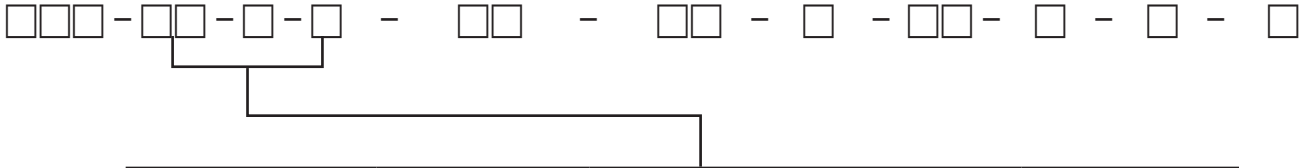

Figure 16

## RENEWAL PARTS IDENTIFICATION

PRODUCT TYPE	KW	VOLTS	Ø	CONTROL VOLTAGE	INTEGRAL THERMOSTAT	INTEGRAL DISCONN. SWITCH	FAN ONLY SWITCH	TIME DELAY	POWER ON PILOT LIGHT	OUTLET SCREEN
--------------	----	-------	---	-----------------	---------------------	--------------------------	-----------------	------------	----------------------	---------------



Code No.	kW	Volts	Phase	Element Part No.	Motor Part No.	Fan Part No.
HVH-02-81	2.67	208	1	118-305631-001	193-302912-001	112-302997-001
HVH-02-21	2.67	208/240	1	118-305631-002	193-302912-001	112-302997-001
HVH-02-71	2.67	277	1	118-305631-003	193-302120-001	112-130367-001
HVH-04-81	4	208	1	118-305631-001	193-302912-001	112-302997-001
HVH-04-83	4	208	3	118-305631-001	193-302912-001	112-302997-001
HVH-04-21	3/4	208/240	1	118-305631-002	193-302912-001	112-302997-001
HVH-04-23	3/4	208/240	3	118-305631-002	193-302912-001	112-302997-001
HVH-04-71	4	277	1	118-305631-003	193-302120-001	112-130367-001
HVH-04-43	4	480	3	118-305631-003	193-302912-003	112-302997-001
HVH-05-81	5	208	1	118-305631-004	193-302912-001	112-302997-001
HVH-05-83	5	208	3	118-305631-004	193-302912-001	112-302997-001
HVH-05-21	3.75/5	208/240	1	118-305631-005	193-302912-001	112-302997-001
HVH-05-23	3.75/5	208/240	3	118-305631-005	193-302912-001	112-302997-001
HVH-05-71	5	277	1	118-305631-006	193-302120-001	112-130367-001
HVH-05-43	5	480	3	118-305631-007	193-302912-003	112-302997-001
HVH-07-81	7.5	208	1	118-305659-007	193-302912-004	112-130367-002
HVH-07-83	7.5	208	3	118-305659-007	193-302912-004	112-130367-002
HVH-07-21	5.6/7.5	208/240	1	118-305659-008	193-302912-004	112-130367-002
HVH-07-23	5.6/7.5	208/240	3	118-305659-008	193-302912-004	112-130367-002
HVH-07-71	7.5	277	1	118-305659-009	193-302120-004	112-130367-002
HVH-07-43	7.5	480	3	118-305659-010	193-302912-005	112-130367-002
HVH-10-81	10	208	1	118-305659-001	193-302912-004	112-130367-002
HVH-10-83	10	208	3	118-305659-001	193-302912-004	112-130367-002
HVH-10-21	7.5/10	208/240	1	118-305659-002	193-302912-004	112-130367-002
HVH-10-23	7.5/10	208/240	3	118-305659-002	193-302912-004	112-130367-002
HVH-10-43	10	480	3	118-305659-003	193-302912-005	112-130367-002
HVH-12-83	12.5	208	3	118-305659-004	193-302912-004	112-130367-002
HVH-12-23	9.4/12.5	208/240	3	118-305659-005	193-302912-004	112-130367-002
HVH-12-43	12.5	480	3	118-305659-006	193-302912-005	112-130367-002
HVH-15-83	15	208	3	118-305659-007	193-302912-004	112-130367-002
HVH-15-23	11.2/15	208/240	3	118-305659-008	193-302912-004	112-130367-002
HVH-15-43	15	480	3	118-305659-010	193-302912-005	112-130367-002
HVH-20-23	19.8	208/240	3	118-305762-019	193-302912-004	112-130367-002
HVH-20-43	19.8	480	3	118-305762-009	193-302912-005	112-130367-002
HVH-20-63	19.8	600	3	Check with Factory	Check with Factory	Check with Factory
HVH-25-23	25.0	208/240	3	118-305762-017	193-302120-037	112-045422-016
HVH-25-43	25.0	480	3	118-305762-020	193-302120-011	112-045422-016
HVH-25-63	25.0	600	3	118-305762-016	193-302912-026	112-045422-016
HVH-30-23	30.0	208/240	3	118-305762-013	193-302120-037	112-045422-016
HVH-30-43	30.0	480	3	118-305762-014	193-302120-011	112-045422-016
HVH-30-63	30.0	600	3	118-305762-015	193-302912-026	112-045422-016
HVH-35-23	33.3	208/240	3	118-305762-011	193-302120-037	112-045422-013
HVH-35-43	33.3	480	3	118-305762-012	193-302120-011	112-045422-013
HVH-35-63	33.3	600	3	118-305762-010	193-302912-026	112-045422-013
HVH-40-23	37.5	208/240	3	118-305762-017	193-302120-037	112-045422-013
HVH-40-43	37.5	480	3	118-305762-020	193-302120-011	112-045422-013
HVH-40-63	37.5	600	3	118-305762-016	193-302912-026	112-045422-013
HVH-45-23	45.0	208/240	3	118-305762-013	193-302120-037	112-045422-013
HVH-45-43	45.0	480	3	118-305762-014	193-302120-011	112-045422-013
HVH-45-63	45.0	600	3	118-305762-015	193-302912-026	112-045422-013
HVH-50-23	50.0	208/240	3	118-305762-011	193-302120-037	112-045422-013
HVH-50-43	50.0	480	3	118-305762-010	193-302120-011	112-045422-013
HVH-50-63	50.0	600	3	118-305762-012	193-302912-026	112-045422-013



## RENEWAL PARTS IDENTIFICATION

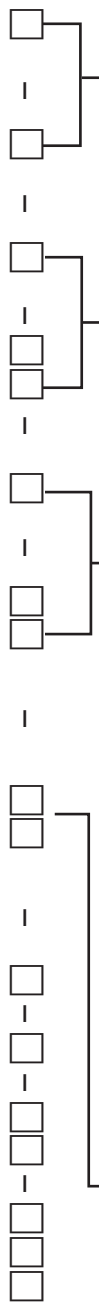

KW	VOLTS	Ø	CONTROL VOLTAGE
-00	-0	0	-00
2, 4, 7, 8			00 = No Contactor
2, 4, 7, 8			30,31 = 24V 35A Contactor P/N 072-306110-001
2, 4, 7, 8			30,31 = 24V 50A Contactor P/N 072-306110-002
2, 4, 8			30 = 24V Transformer P/N 315-304252-002
7			30 = 24V Transformer P/N 315-304252-004
2, 4, 7, 8			32,33 = 120V 35A Contactor P/N 072-306110-007
2, 4, 7, 8			32,33 = 120V 50A Contactor P/N 072-306110-008
2, 4, 8			32 = Transformer P/N 315-304252-001
7			32 = Transformer P/N 315-304252-003
2, 8			34 = 208/240V 35A Contactor P/N 072-306110-013
2, 8			34 = 208/240V 50A Contactor P/N 072-306110-014
7			35 = 277V 35A Contactor P/N 072-306110-019
7			35 = 277V 50A Contactor P/N 072-306110-020

Cutout Switch	
2.6 through 5 kW	300-024413-001
7.5 through 15 kW	300-024413-002

INTEGRAL THERMOSTAT	DISCONNECT SWITCH
-00	-0
00 = No Thermostat	0 = No Disconnect Switch
TL = SPST P/N 300-049197-003	D = 50A P/N 292-303472-007
TL = DPST P/N 300-049197-004	D = 80A P/N 168-303598-007
TH = SPST P/N 300-049197-001	D = 100A P/N 168-303598-008
TH = DPST P/N 300-049197-002	

PILOT LIGHT	OUTLET SCREEN
-0	-0
0 = No Pilot Light	0 = No Outlet Screen
P = 24V P/N 213-072380-029	S = 2-5 kW P/N 247-305642-001
P = 120V P/N 213-072380-007	S = 7-20 kW P/N 247-305642-002

FAN ONLY SWITCH	TIME DELAY
-0	-0
D0 = No Disconnect Switch	0 = No Time Delay Relay
FI = 3PST Switch P/N 292-057673-001	R = 24V Relay P/N 072-071847-040
FE = 3PST Switch P/N 292-057673-001	R = 120V Relay P/N 072-071847-041
FI = 24V Motor Relay P/N 072-123534-075	
FI = 120V Motor Relay P/N 072-123534-064	

Miscellaneous Parts	
Thermostat Knob	169-049278-001

Instruction Sheets	
1. Internal Thermostat	PF204
2. Internal/External Summer Fan Switch	PF205
3. Internal/External Summer Fan Switch W/Relay	PF206
4. Disconnect Switch	PF207

### Limited Warranty:

Please refer to the Chromalox limited warranty applicable to this product at <http://www.chromalox.com/customer-service/policies/termsofsale.aspx>.

# Chromalox®

## PRECISION HEAT AND CONTROL

2150 N. RULON WHITE BLVD., OGDEN, UT 84404  
Phone: 1-800-368-2493    [www.chromalox.com](http://www.chromalox.com)



Sales • Engineering  
"Heat and Control Specialists"

**GORDO SALES, INC.**

P.O. Box 1166 Layton, UT 84041  
Phone: 801-544-4236 Fax: 888-264-0740  
<http://www.gordosales.com>  
lhuggins@gordosales.com