

# Chromalox®

## *Installation, Operation* and **RENEWAL PARTS IDENTIFICATION**

### SERVICE REFERENCE

DIVISION 4	SECTION DRA
SALES REFERENCE (Supersedes PF-497)	PF497-1
161-304812-001	
DATE	NOVEMBER, 2002

## **Portable Industrial Unit Blower Air Heater Type DRA**



Specifications – Table 1

Model	Electrical Data (60 Hz)					Dimensions (In.)		
	Volts	kW	Phase	Amps* 1/3 Ph	BTU	Height	Width	Depth
DRA-07-83	208	7.5	1 and 3	36.3/21.0	25,590	34.25	27.5	25
DRA-07-23	240/208	7.5/5.6	1 and 3	31.5/18.3**	25,590	34.25	27.5	25
DRA-10-83	208	9.75	1 and 3	47.1/27.3	33,267	34.25	27.5	25
DRA-10-23	240/208	9.75/7.3	1 and 3	40.8/23.7**	33,267	34.25	27.5	25
DRA-15-83	208	15	3	41.8	51,180	34.25	27.5	25
DRA-15-23	240/208	15/11.2	3	36.3**	51,180	34.25	27.5	25
DRA-15-43	480	15	1 and 3	31.4/18.2	51,180	34.25	27.5	25
DRA-15-63	600	15	1 and 3	25.2/14.6	51,180	34.25	27.5	25
DRA-20-23	240/208	19.5/15	3	47.1**	66,534	34.25	27.5	26.5
DRA-20-43	480	20	1 and 3	42.0/24.4	68,240	34.25	27.5	26.5
DRA-20-63	600	20	1 and 3	33.5/19.4	68,240	34.25	27.5	26.5
DRA-30-43	480	30	3	36.3	102,360	34.25	27.5	26.5
DRA-30-63	600	30	3	20.1	102,360	34.25	27.5	26.5

\* = Includes motor amps

\*\* = Ratings shown are for 240V, 208V amperage is 86% of 240V value.

Models shown as 1 and 3 phase are factory wired for 3 phase operation and can be field wired for single phase.

### GENERAL

## **IMPORTANT: SAVE THESE INSTRUCTIONS**

### **⚠ WARNING**

**Risk of fire. Do not use as a residential or household heater.**

### **⚠ WARNING**

**Hazard of Fire or Discoloration of Temperature Sensitive Fabrics. Do not use as a residential or household heater. Keep combustible material and**

**such fabrics away from heater. Do not operate heater where flammable vapors, gases or liquids are present. Heaters in the heat mode should not be operated in room temperatures above 80°F. Fan motor is not designed to operate in ambients below -40°F.**

**To avoid personal injury read "IMPORTANT INSTRUCTIONS" on page 2 before installation or operation of heater.**

### **⚠ WARNING**

**Keep electrical cords and combustible materials, such as drapes and other furnishings, away from heater.**

# IMPORTANT INSTRUCTIONS

When using electrical appliances, basic precautions should always be followed to reduce the risk of fire, electric shock and injury to persons, including the following:

1. Read all instructions before using this heater.
2. This heater is hot when in use. To avoid burns, do not let bare skin touch hot surfaces. If provided, use handles when moving this heater. Keep combustible materials, such as furniture, pillows, bedding, papers, clothes, and curtains at least 3 feet (0.9 m) from the front of the heater and keep them away from the sides and rear.
3. Extreme caution is necessary when any heater is used by or near children or handicapped individuals and whenever the heater is left operating and unattended.
4. Always disconnect heater when not in use.
5. Do not operate any heater with a damaged cord or plug or after the heater malfunctions, has been dropped or damaged in any manner. Return heater to authorized service facility for examination, electrical or mechanical adjustments, or repair.
6. Do not use outdoors.
7. This heater is not intended for use in bathrooms, laundry areas and similar indoor locations. Never locate heater where it may fall into a bathtub or other water container.

8. Do not run cord under carpeting. Do not cover cord with throw rugs, runners or the like. Arrange cord away from traffic area and where it will not be tripped over.
9. To disconnect heater, turn thermostat off, then remove plug from outlet.
10. Connect to properly grounded outlets only.
11. Do not insert or allow foreign objects to enter any ventilation or exhaust opening as this may cause an electric shock, fire or damage the heater.
12. To prevent a possible fire, do not block air intakes or exhaust in any manner. Do not use on soft surfaces, like a bed, where opening may become blocked.
13. A heater has hot and arcing or sparking parts inside. Do not use it in areas where gasoline, paint or flammable liquids are used or stored.
14. Use this heater only as described in this manual. Any other use not recommended by the manufacturer may cause fire, electric shock or injury to persons.
15. This heater is not intended for use with an extension cord.
16. **SAVE THESE INSTRUCTIONS.**

## ASSEMBLY INSTRUCTIONS

The Chromalox DRA is shipped fully assembled. The handle is assembled in the lower position (dotted line Fig. 1). To position handle in the upright position, remove bolts securing the handle to the support legs, lift handle until the handle holes line up with the upper holes in the support legs and insert bolts to secure the handle in the full upright position.

- Tools Required
- Crescent Wrench
  - Phillips Screwdriver

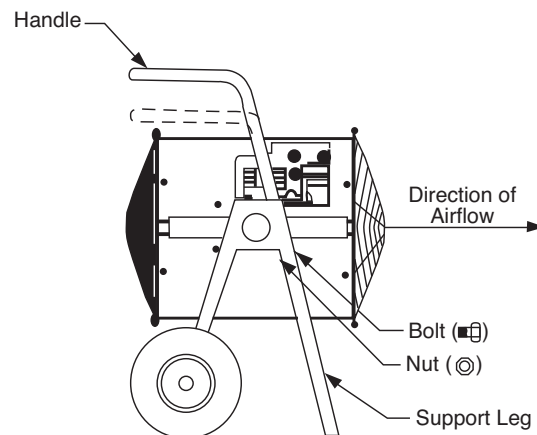

Figure 1

## WIRING

### **⚠ WARNING**

**ELECTRIC SHOCK HAZARD. Disconnect all power before installing or servicing heater. Failure to do so could result in personal injury or property damage. Heater must be effectively grounded in accordance with the National Electrical Code, NFPA 70.**

1. Use heater only on the voltage and frequency specified on the nameplate.
2. All wiring should be done in accordance with local codes and the National Electrical Code by a qualified person.
3. Branch circuit wire for connection to heater must be at least 90°C wire.

4. The top access panel is secured by 4 screws that must be loosened to gain access.
5. A ground terminal is provided near the power terminal board. The ground wire should be connected before other connections are made.
6. Refer to Chart A for proper size "SO" grade cable.
7. A proper strain relief must be used with "SO" grade cable.
8. Dragon heaters are factory pre-wired for 3-phase delta operation. Some units can be converted to single phase operation by changing the wiring. Refer to Chart A for those heaters that can be converted to single phase. The appropriate wiring diagram is also located on the back of the wiring compartment cover.









# WIRING

**Chart A — Cable and Plug Selection**

Model	kW	Volts	Phase	Wiring Diag. No.	Amps	Wire Size	25' Cord Set Chromalox Catalog No.	Optional Plugs	
								Locking Type	Non Lock Type
DRA-07-83	7.5	208	1	1A	36.3	8/3	PLC-2508-3	—	PGN-6-50
DRA-07-83	7.5	208	3	1	21.0	10/4	PLC-2510-4	PGL-15-30	PGN-15-50
DRA-07-23	5.6	208	1	1A	27.1	10/3	PLC-2510-3	PGL-15-30	PGN-6-50
DRA-07-23	5.6	208	3	1	15.7	12/4	PLC-2512-4	PGL-15-20	PGN-15-20
DRA-07-23	7.5	240	1	1A	31.5	8/3	PLC-2508-3	—	PGN-6-50
DRA-07-23	7.5	240	3	1	18.2	12/4	PLC-2512-4	PGL-15-20	PGN-15-20
DRA-10-83	9.75	208	1	1A	47.1	6/3	PLC-2506-3	—	PGN-6-50
DRA-10-83	9.75	208	3	1	27.2	8/4	PLC-2508-4	PGL-15-30	PGN-15-50
DRA-10-23	7.3	208	1	1A	35.4	8/3	PLC-2508-3	—	PGN-6-50
DRA-10-23	7.3	208	3	1	20.4	10/4	PLC-2510-4	PGL-15-30	PGN-15-50
DRA-10-23	9.75	240	1	1A	40.8	6/3	PLC-2506-3	—	PGN-6-50
DRA-10-23	9.75	240	3	1	23.6	10/4	PLC-2510-4	—	PGN-15-50
DRA-15-83	15	208	3	1	41.8	6/4	PLC-2506-4	—	PGN-15-50
DRA-15-23	11.2	208	3	1	31.4	8/4	PLC-2508-4	—	PGN-15-50
DRA-15-23	15	240	3	1	38.3	6/4	PLC-2506-4	—	PGN-15-50
DRA-15-43	15	480	1	2A	31.5	8/3	PLC-2508-3	PGL-3763C	—
DRA-15-43	15	480	3	2	18.2	12/4	PLC-2512-4	PGL-16-30	—
DRA-15-93	15	600	1	2A	25.2	10/3	PLC-2510-3	PGL-3763C	—
DRA-15-93	15	600	3	2	14.6	14/4	PLC-2514-4	PGL-17-30	—
DRA-20-23	15	208	3	3	41.8	6/4	PLC-2506-4	—	PGN-15-50
DRA-20-23	20	240	3	3	48.3	4/4	PLC-2504-4	—	PGN-15-50
DRA-20-43	20	480	1	4A	41.9	6/3	PLC-2506-3	PGL-3763C	—
DRA-20-43	20	480	3	4	24.4	10/4	PLC-2510-4	PGL-17-30	—
DRA-20-93	20	600	1	4A	33.5	8/3	PLC-2508-3	PGL-3763C	—
DRA-20-93	20	600	3	4	19.4	12/4	PLC-2512-4	PGL-17-30	—
DRA-30-43	30	480	3	4	36.3	6/4	PLC-2506-4	PGL-3764C	—
DRA-30-93	30	600	3	4	29.1	8/4	PLC-2508-4	PGL-17-30	—

Power Cord based on 600V Hard Service Cord Rated 90°C  
 Plug selection is based on using Chromalox Cable Kits

**Plug Selection**

Fits Cable Dia.	Plug Type	Model	Description	Volts	Amps	Configuration	NEMA #	ANSI #
.385"-.780"	Locking	PGL-15-20	3 Pole, 4 Wire	250	20		L15-20	C73.85
.385"-.780"	Locking	PGL-15-30	3 Pole, 4 Wire	250	30		L15-30	C73.86
.595"-1.150"	Locking	PGL-16-30	3 Pole, 4 Wire	480	30		L16-30	C73.88
.595"-1.150"	Locking	PGL-17-30	3 Pole, 4 Wire	600	30		L17-30	C73.89
.750"-1.125"	Locking	PGL-3763C	2 Pole, 4 Wire	600	50		—	—
.750"-1.125"	Locking	PGL-3765C	3 Pole, 4 Wire	600	50		—	—
.625"-1.187"	Non Locking	PGN-6-50	2 Pole, 3 Wire	250	50		6-50	C73.53
.390"-.775"	Non Locking	PGN-15-20	3 Pole, 4 Wire	250	20		15-20	C73.59
.750"-1.250"	Non Locking	PGN-15-50	3 Pole, 4 Wire	250	50		15-50	C73.61

The above plugs are designed to be used with specific ranges of cable diameters. If not used with Chromalox Cable Kits, check cable manufacturers cable diameter to be sure plug fits selected cable.

## WIRING

### Cord Preparation for Chromalox Portable Heaters

1. Determine the gage and number of conductors from the tabulation below using amps and phase from the heater nameplate. It is not recommended that cord exceed 50 feet in length.

Max. Heater Amps	Chromalox Cord Kit*	Cord Ga./No. Cond. and Type	
	Model No.	1 Phase	3 Phase
15	PLC-2514-4		14/4 SO
20	PLC-2512-4		12/4 SO
30	PLC-2510-3	10/3 SO	
25	PLC-2510-4		10/4 SO
40	PLC-2508-3	8/3 SO	
35	PLC-2508-4		8/4 SO
55	PLC-2506-3	6/3 SO	
45	PLC-2506-4		6/4 SO
60	PLC-2504-4		4/4 SO

\*Includes 90 degree fitting and 25 foot of cord, reducers and locknut

2. Strip off outer jacket of cord and insulation from lead wires. The tabulation below provides the strip dimensions for the various Chromalox portable heaters. See the nameplate on the heater for the Model number.

Model No.	A	B	C
DRA - (all suffixes)	8"	1"	0.5"

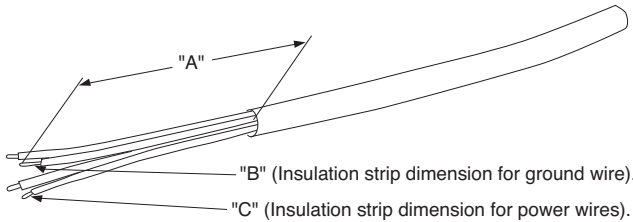

3. Slide fitting onto cord and tighten knurled nut to secure fitting to cord.
4. Select plug to match electrical rating of cord.
5. On opposite end of cord prepare end as directed by instructions that are provided with the plug.
6. Attach cord assembly to heater as shown in Fig. 2 below:

Run wire tie through slots in bracket and over cord. Pull tab of wire tie to provide cord strain relief.

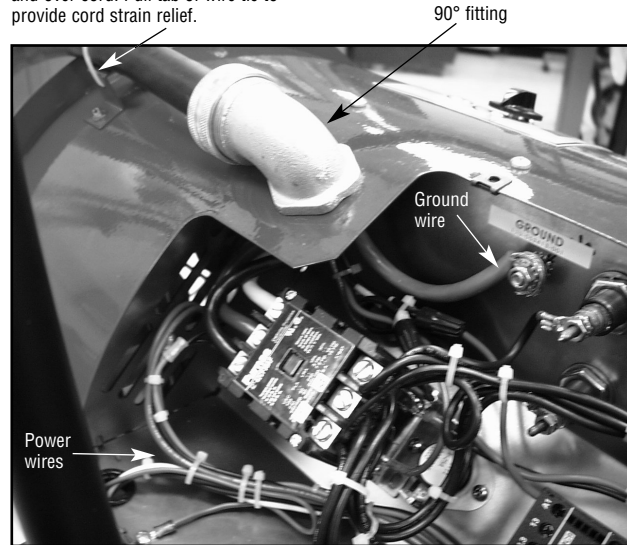

Figure 2

## OPERATION

### THERMOSTAT

Heaters include a bimetal thermostat for the automatic control of the exiting air temperature. The thermostat knob controls the heating elements and fan functions. The heater and fan are de-energized with the knob in the extreme clockwise position.

Turning the knob clockwise from the off position to the fan position will energize the fan only, for use in summer cooling.

The adjustment knob controls power to the heater and fan when turned further in the clockwise direction, with the highest temperature setting in the extreme clockwise position.

The temperature setting in the heater mode is approximately 40°F in the low setting and 100°F at the highest setting.

**Note:** The adjustment knob should be turned to the fan only setting after use for heating. The fan should be left on for at least 3 minutes to remove residual heat from the unit and to prevent overheating of the housing.

# WIRING DIAGRAMS

**Diag. 1 – FACTORY WIRED 3 PHASE**

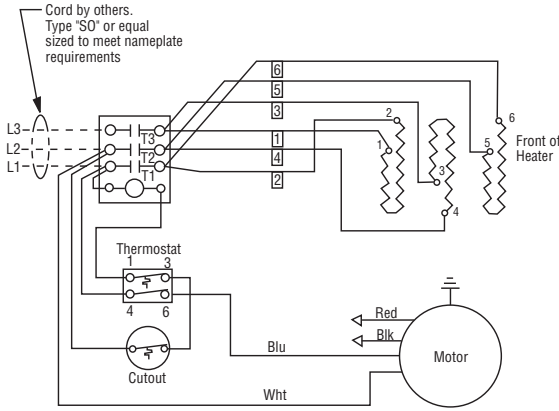

**Diag. 1a – FIELD CONVERSION TO 1 PHASE**

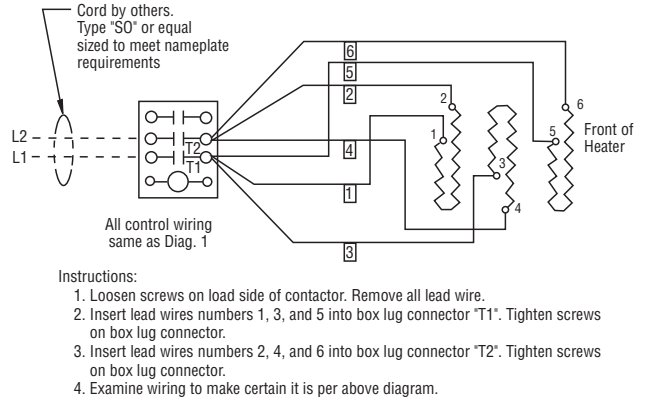

- Instructions:
1. Loosen screws on load side of contactor. Remove all lead wire.
  2. Insert lead wires numbers 1, 3, and 5 into box lug connector "T1". Tighten screws on box lug connector.
  3. Insert lead wires numbers 2, 4, and 6 into box lug connector "T2". Tighten screws on box lug connector.
  4. Examine wiring to make certain it is per above diagram.

**Diag. 2 – FACTORY WIRED 3 PHASE**

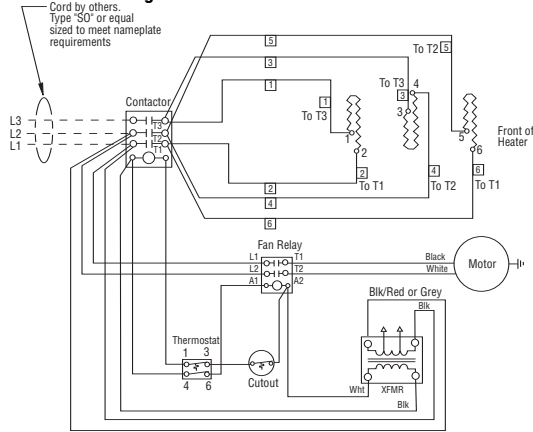

**Diag. 2a – FIELD CONVERSION TO 1 PHASE**

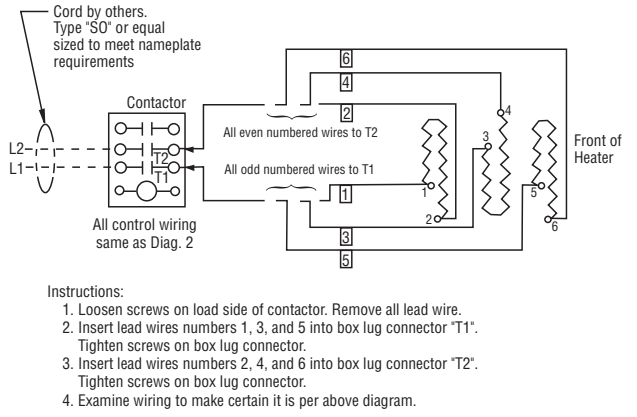

- Instructions:
1. Loosen screws on load side of contactor. Remove all lead wire.
  2. Insert lead wires numbers 1, 3, and 5 into box lug connector "T1". Tighten screws on box lug connector.
  3. Insert lead wires numbers 2, 4, and 6 into box lug connector "T2". Tighten screws on box lug connector.
  4. Examine wiring to make certain it is per above diagram.

**Diag. 3 – FACTORY WIRED 3 PHASE**

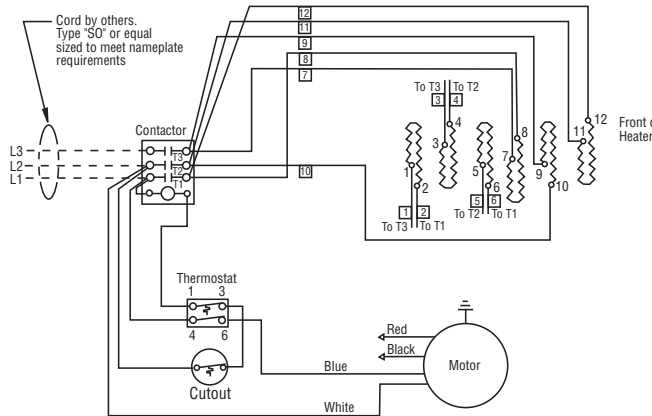

**Diag. 4 – FACTORY WIRED 3 PHASE**

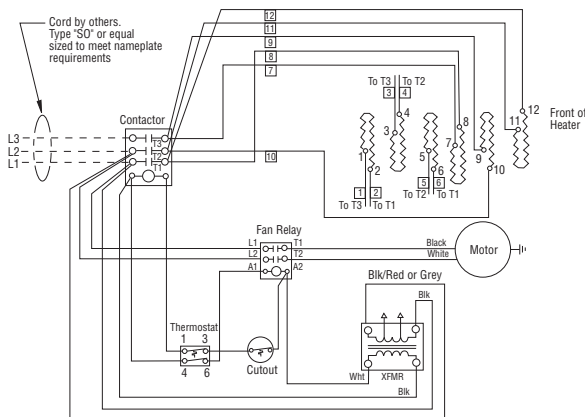

**Diag. 4a – FIELD CONVERSION TO 1 PHASE**

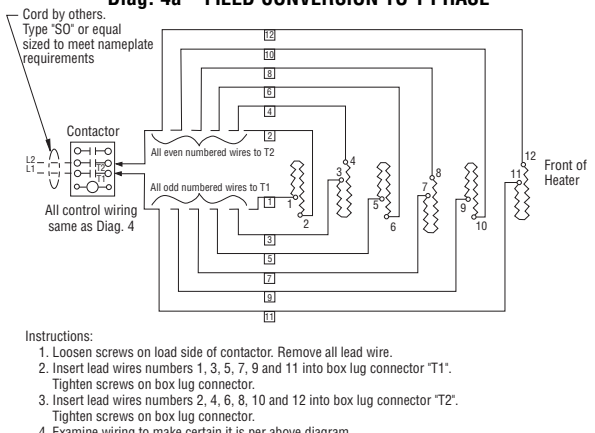

- Instructions:
1. Loosen screws on load side of contactor. Remove all lead wire.
  2. Insert lead wires numbers 1, 3, 5, 7, 9 and 11 into box lug connector "T1". Tighten screws on box lug connector.
  3. Insert lead wires numbers 2, 4, 6, 8, 10 and 12 into box lug connector "T2". Tighten screws on box lug connector.
  4. Examine wiring to make certain it is per above diagram.

## MAINTENANCE

### ⚠ WARNING

**ELECTRIC SHOCK HAZARD. Disconnect heater from power supply before servicing and/or inspecting the heater; failure to do so may result in electrical shock.**

Replace or repair damaged cords or plugs immediately. Check tightness of all electrical connections prior to energizing Dragon. Blow out or vacuum away any dirt or debris that may have accumulated around the control enclosure fan motor or heating elements.

## RENEWAL PARTS IDENTIFICATION

Model No.	Volts	kW	Phase	Element Part No.	Motor Part No.	Fan Part No.	Contactors Part No.	Control Trans/	
DRA-07-83	208	7.5	1 and 3	118-304793-001	193-302120-009		072-304551-014	———	
DRA-07-23	240	7.5	1 and 3	118-304793-002			072-304551-014	———	
DRA-10-83	208	9.75	1 and 3	118-304793-003			072-304551-014	———	
DRA-10-23	240	9.75	1 and 3	118-304793-004			072-304551-014	———	
DRA-15-83	208	15	3	118-304793-007			072-304551-014	———	
DRA-15-23	240	15	3	118-304793-008			072-304551-014	———	
DRA-15-43	480	15	1 and 3	118-304793-009			193-302120-012	072-304551-008	315-304252-001
DRA-15-93	600	15	1 and 3	118-304793-010			193-302120-015	112-045422-007	072-304551-008
DRA-20-23	240	19.5	3	118-304793-004	193-302120-009		072-304551-014	———	
DRA-20-43	480	20	1 and 3	118-304793-005	193-302120-012		072-304551-008	315-304252-001	
DRA-20-93	600	20	1 and 3	118-304793-006	193-302120-015		072-304551-008	315-304252-003	
DRA-30-43*	480	30	3	118-304793-011a	193-302120-012		072-304551-008	315-304252-001	
				118-304793-013b					
DRA-30-93*	600	30	3	118-304793-012a	193-302120-015		072-304551-008	315-304252-003	
				118-304793-014b					

30 kW units contain two sets of three elements (six total). The ratings of the three elements on the discharge end have a lower wattage than the elements on the fan end of heater. The ends of the elements are color coded, the lower wattage are color coded yellow and the higher wattage are color coded blue.

a. Lower wattage elements, discharge end, yellow coded

b. Higher wattage elements, fan end, blue coded

PARTS COMMON TO ALL UNITS	
Description	Part No.
Wheels	333-557518-004
Grille	134-304780-002
Thermostat	300-304782-001
Thermal Cut-out	300-048038-003
Fan Relay (not used on 208 and 240V Models)	072-123534-057

Sales • Engineering

“Heat and Control Specialists”



## GORDO SALES, INC.

P.O. Box 1166 Layton, UT 84041  
 Phone: 801-544-4236 Fax: 888-264-0740  
<http://www.gordosales.com>  
[lhuggins@gordosales.com](mailto:lhuggins@gordosales.com)

### Limited Warranty:

Please refer to the Chromalox limited warranty applicable to this product at <http://www.chromalox.com/customer-service/policies/termsofsale.aspx>.

# Chromalox®

## PRECISION HEAT AND CONTROL

2150 N. RULON WHITE BLVD., OGDEN, UT 84404  
 Phone: 1-800-368-2493      [www.chromalox.com](http://www.chromalox.com)