

Chromalox®

Installation Instructions and RENEWAL PARTS IDENTIFICATION

Forced Air Heater for Hazardous Locations

CXH-A-03 EP to CXH-A-35 EP
Class I - Groups C & D, Div. 1 & 2
Class II - Groups E, F & G
T3B - 165°C (329°F)



SERVICE REFERENCE	
DIVISION 4	SECTION CXH-A
SALES REFERENCE (Supersedes PF490-4)	PF490-5
161-302421-004	
DATE	JULY, 2004

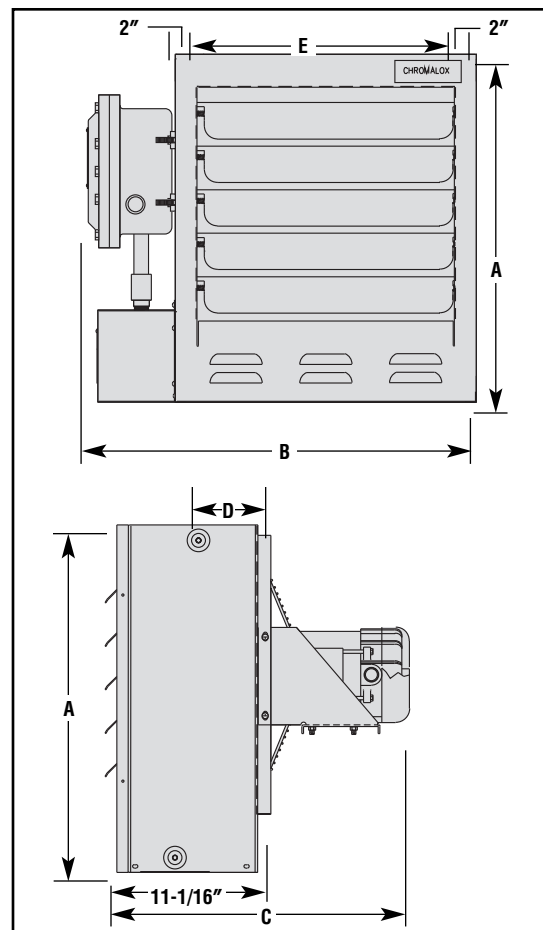

Table A – Specifications

Model	kW	Voltage and Phase	Horiz. Air Discharge (Ft.)	BTUH	CFM	Wt. (Lbs.)	Overall Dimensions (In.)			5/8" UNC Tapped Mounting Hole Locations	
							A	B	C	D	E
CXH-A-03	3	208/240V-1 or 3Ø 480/575V-3Ø	28	10,236	700	127	19-1/8	23-7/8	21	3-1/2	13-5/8
CXH-A-05	5	208/240V-1 or 3Ø 480/575V-3Ø	28	17,060	700	127	19-1/8	23-7/8	21	3-1/2	13-5/8
CXH-A-07	7.5	208/240V-1 or 3Ø 480/575V-3Ø	32	25,590	840	133	19-1/8	23-7/8	21	3-1/2	13-5/8
CXH-A-10	10	240V-1 or 3Ø 208/480/575V-3Ø	32	34,120	840	138	19-1/8	23-7/8	21	3-1/2	13-5/8
CXH-A-15	15	208/240/480V 575V-3Ø	47	51,180	1450	150	25	27-7/8	21	4-13/32	17-5/8
CXH-A-18	18	240V-3Ø	43	61,420	1400	165	25	27-7/8	21	4-13/32	17-5/8
CXH-A-20	20	480/575V-3Ø	43	68,240	1400	165	25	27-7/8	21	4-13/32	17-5/8
CXH-A-25	25	480/575V-3Ø	54	85,300	2330	200	32-1/8	31-7/8	21-3/4	5-1/2	21-5/8
CXH-A-30	30	480/575V-3Ø	54	102,360	2330	200	32-1/8	31-7/8	21-3/4	5-1/2	21-5/8
CXH-A-35	35	480/575V-3Ø	54	119,420	2330	200	32-1/8	31-7/8	21-3/4	5-1/2	21-5/8

WARNING

Failure to understand and follow these installation instructions and the **WARNING** notes contained therein may result in severe personal injury, death or substantial property damage.

1. To reduce the risk of ignition of hazardous atmospheres:

- In accordance with the National Electrical Code, do not install where operating temperature code exceeds the ignition temperature of the hazardous atmosphere. Use only in atmospheres having an ignition temperature higher than 165° C (329° F).
- Disconnect from supply circuit before opening enclosures.
- Hazard of Electric Shock.** Heater must be effectively grounded in accordance with N.E.C. to eliminate shock hazard.
- Heat exchanger contains Propylene Glycol under pressure at operating temperature. A material safety data sheet (MSDS) is available from Chromalox upon request. Should leakage occur, remove unit from service and investigate cause.
- Keep all electrical enclosure covers tightly closed and secured with all bolts and threads. Cover joints must be clean before replacing covers.
- Install and operate in upright position only. Refer to Figure 3 for level requirements. Failure to comply will cause overheating of the element and shutting down the unit by tripping the high temperature cutout.

- All unused threaded openings not used for supply wiring must be fitted with threaded plugs approved for use in hazardous locations.
- All unit electrical installation fittings, conduit, wiring and seals must meet NEC and local codes for hazardous locations.
- External line fusing or circuit breaker protection is required.
- Hi limit cutouts must never be bypassed in the control circuit.
- Alarm pilot lamp, if supplied, will turn on if the high limit control actuates. Steady on lamp indicates manual reset protector has tripped. This could result if the heat exchanger is obstructed (dirty), inlet air restricted or fan not turning. Shut off power to unit and refer to repair procedures section of instruction sheet.
- Mounting clearances on nameplate must be observed.
- Use copper wire for supply connections according to size and rating on nameplate.
- Do not install any type of gasket material on any of the electrical junction box cover surfaces.
- Do not attempt to override louver stops or operate unit with louvers fully closed.

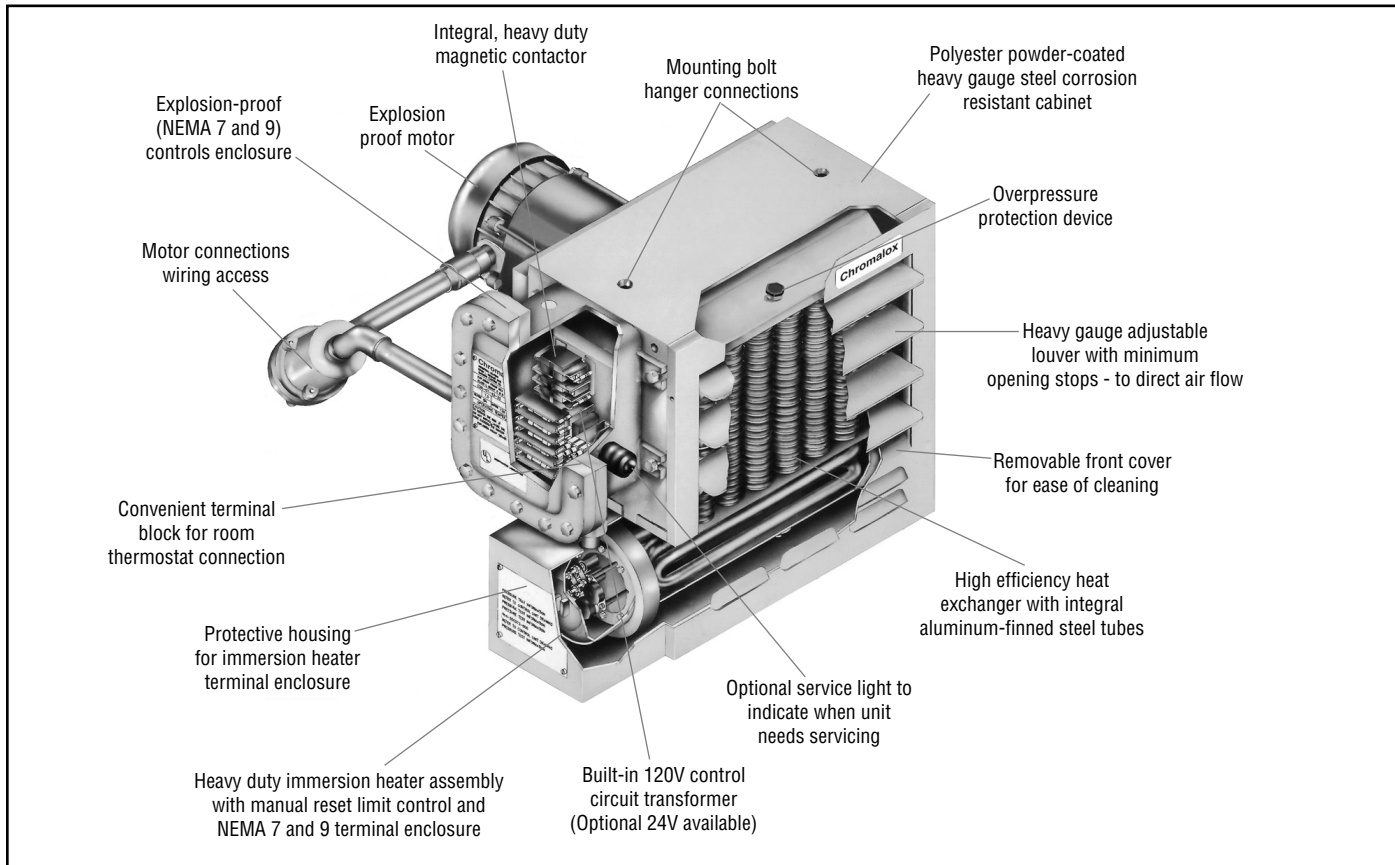

GENERAL

The CXH-A series units rated 3 through 35 kW are designed for operation in Class I, Div. 1, Groups C & D and Class II, Div. 1, Groups E, F and G hazardous atmospheres having an ignition temperature of 165°C (329°F) or higher. They are designed for comfort heating and should not be operated in ambient temperatures exceeding 40°C (104°F). All units in Table A are UL listed. The units are easily adapted for wall, ceiling or pole mounting. Refer to Figure 4 on Page 3 for mounting information. They are

supplied with either 24 or 120V internal control circuit voltage. The heater is designed for use with an external hazardous location thermostat or optional built-in thermostat.

The standard heater is designed to operate up to 7500 feet (2,286m) altitude. Consult factory for specific recommendations when using the units at higher altitudes.

INSTALLATION

⚠ WARNING

FIRE/EXPLOSION HAZARD. Mount only in upright position and observe nameplate mounting clearances.

Heater Location instructions:

Arrange units so their discharge air streams:

- A. are subjected to a minimum of interference from columns, machinery and partitions.
- B. wipe exposed walls without blowing directly at them.
- C. are directed away from room occupants in comfort heating.
- D. are directed along the windward side when installed in a building exposed to a prevailing wind.

Locate thermostat on interior partition walls or posts away from cold drafts, internal heat sources and away from heater discharge air streams.

Small rooms can be heated by one unit heater. Where two walls are exposed, the heater should be mounted as shown in Figure 2. Large rooms require multi-unit installations. Number and capacity of units will be determined by volume of building and square feet of floor area to be heated. Arrange units to provide perimeter air circulation where each unit supports the air stream from another.

The CXH-A hazardous location heaters are designed for use only in a permanently mounted upright position. We recommend

the use of a mounting kit (ceiling, wall or pole) available from Chromalox. (Figures 5, 6 and 7)

The ceiling or wall mounting surface and the anchoring provision must be sufficient to support the combined weights of the unit and mounting hardware.

If using mounting hardware or a supporting structure not supplied by Chromalox, the unit should be suspended from the supporting structure thru the two mounting points on top of the unit with 5/8 NC bolts and lockwashers. If single point mounting is desired, order the correct size Chromalox adapter bracket (P/N 027-302361-001 for 12" fan units, P/N 027-302361-002 for 16" fan units) and P/N 027-302361-003 for 20" fan units. This bracket is designed to hold the unit over its center of gravity with a 1 dia. bolt. The maximum tilt angles as shown in Figure 3 must not be exceeded in either direction during operation and installation. Failure to comply will cause high limit shut down.

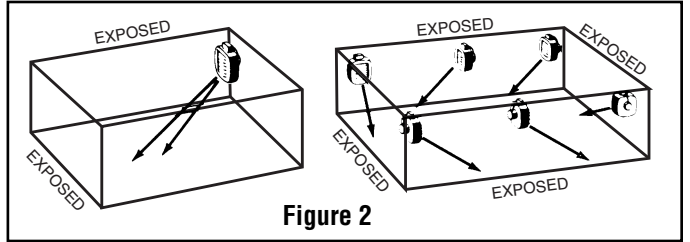

Figure 2

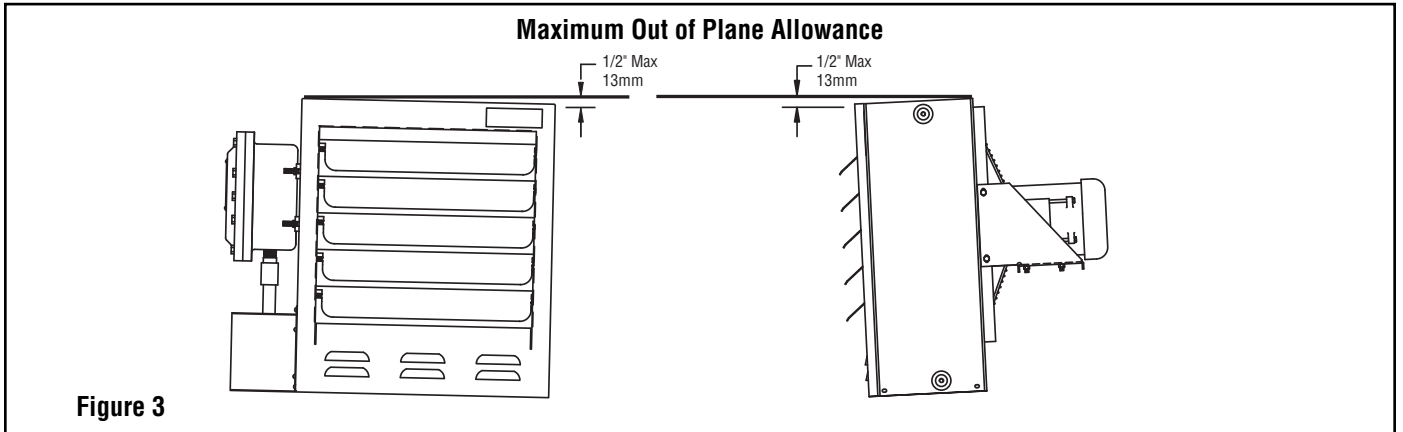

Figure 3

The heaters may be mounted at any convenient height above floor. The minimum spacings shown in Figure 4 should be maintained to adjacent walls and ceiling. If floor heat is desired, do not mount higher than 8 to 10 feet above floor.

Controlling thermostats to individual heaters should be mounted at shoulder height on inside walls or columns and clear of the discharge air stream of the unit. Allow at least 4 in front of heater for air stream to discharge freely.

Do not mount mercury type thermostat directly on unit, vibration could cause malfunction.

Heater may be mounted on a shelf or stand from the bottom. Be sure that mounting clearances are maintained and that bottom of unit has at least 1 clearance underneath it. This is necessary for good air circulation and servicing of heat exchanger. All mounting methods must allow for removal of front cover.

The mounting and anchoring provisions must take into account the unit vibration and cantilevered loading when wall or pole mounted. One of the Chromalox mounting kits shown in Figures 5, 6 and 7 must be used whenever possible.

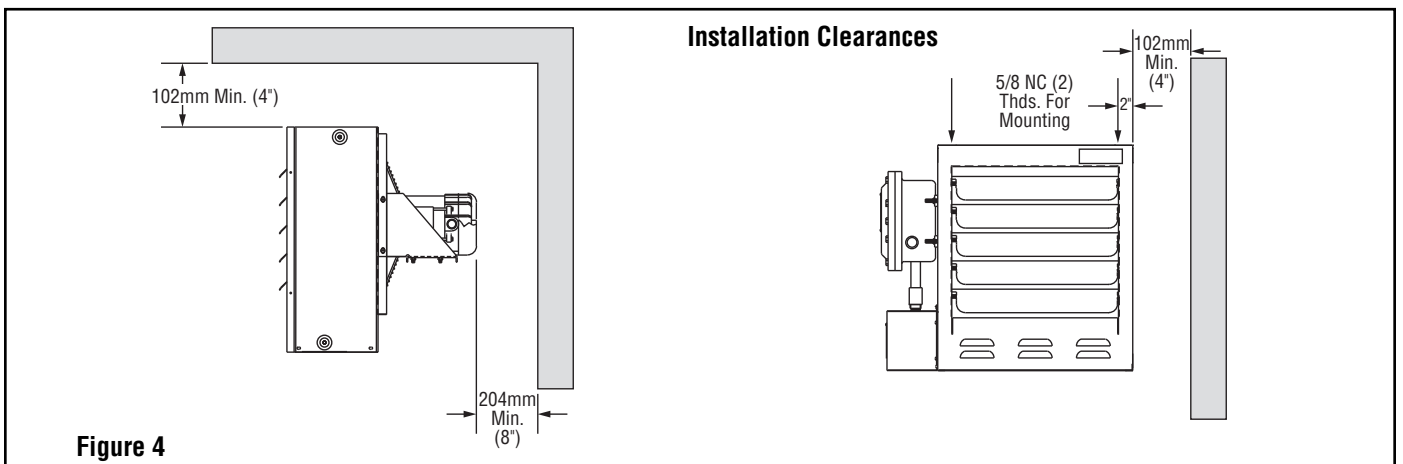

Figure 4

MOUNTING KITS

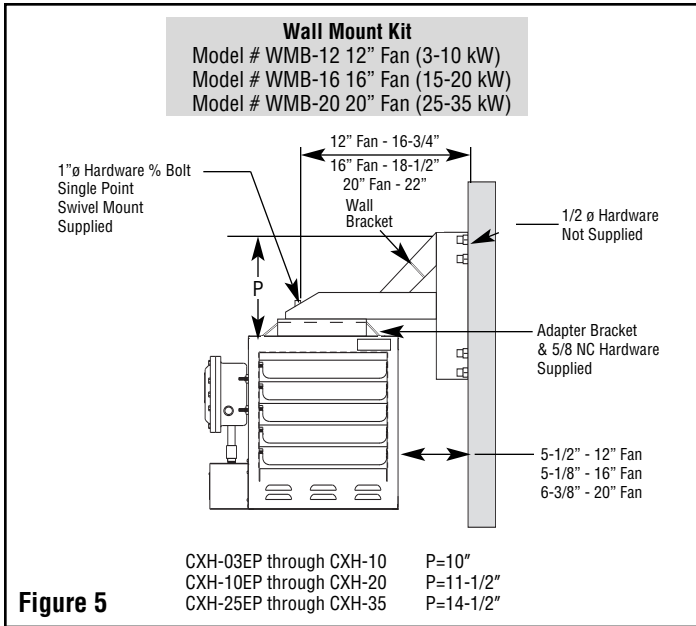

Figure 5

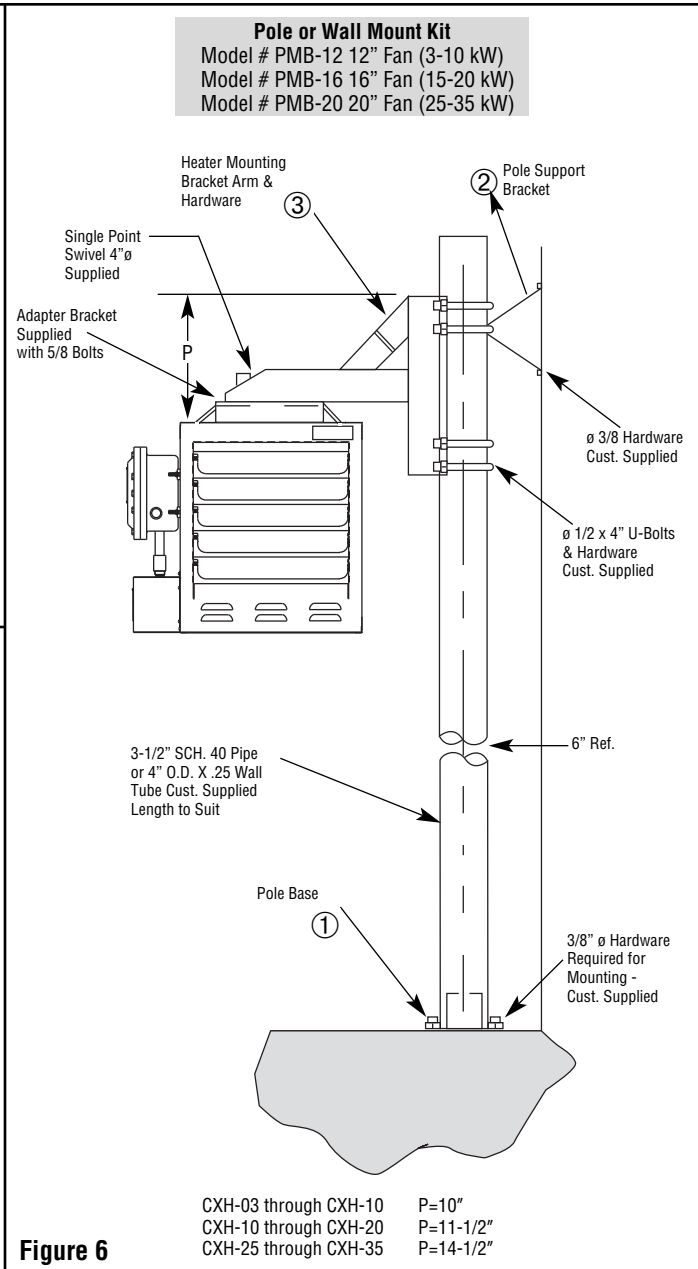

Figure 6

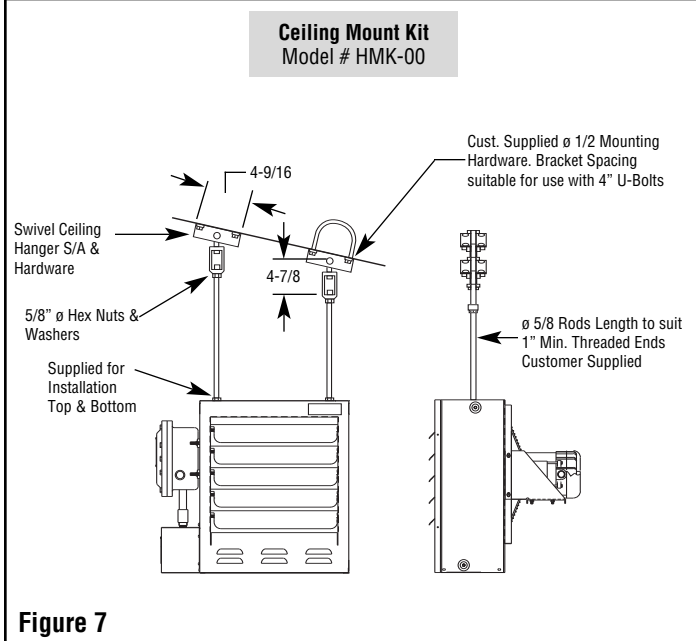

Figure 7

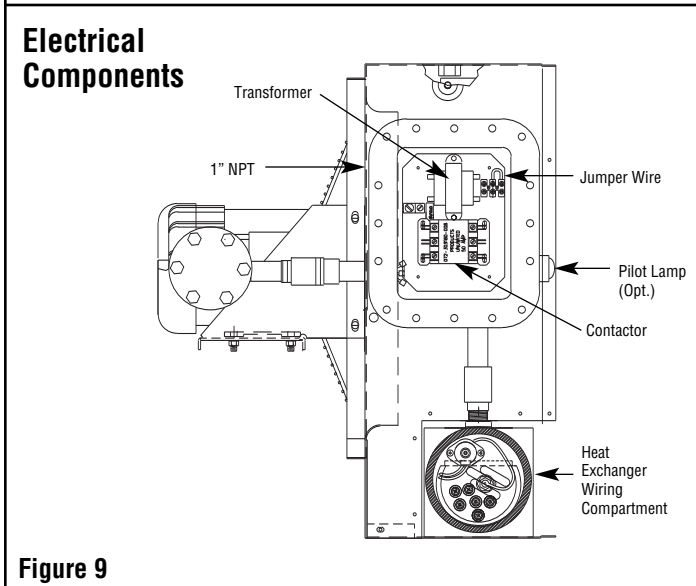

Figure 9

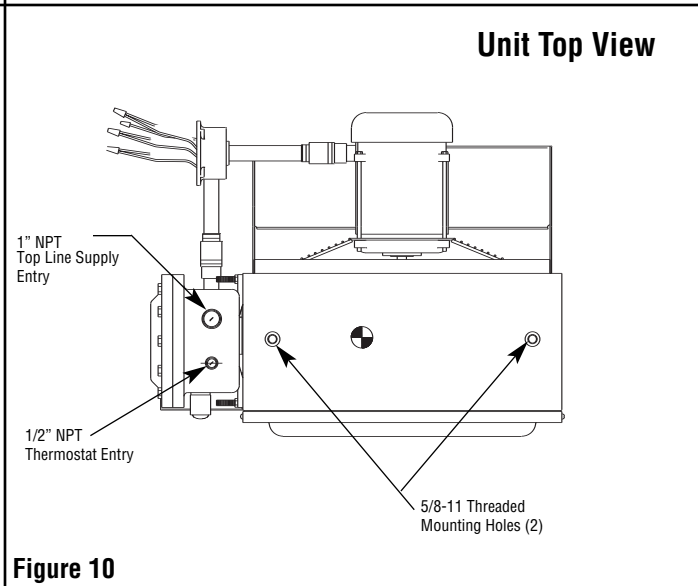

Figure 10

WIRING AND WIRING DIAGRAMS

⚠ WARNING

ELECTRIC SHOCK HAZARD. Disconnect all power before installing or servicing heater. Failure to do so could result in personal injury or property damage. Heater must be installed by a qualified person in accordance with the National Electrical Code, NFPA 70.

⚠ WARNING

ELECTRIC SHOCK HAZARD. Any installation involving electric heaters must be performed by a qualified person and must be effectively grounded in accordance with the National Electrical Code to eliminate shock hazard.

- Loosen and remove bolts securing the main terminal enclosure cover on side of unit. Connect heater to line supply wires at the box lugs located on the contactor according to the voltage and frequency specified on the nameplate (see Figure 9). Refer to the appropriate wiring diagram which also appears on the inside cover of this enclosure (see Table B and diagrams on page 6).

⚠ WARNING

EXPLOSION HAZARD. Cover joints must be clean before replacing cover. Do not use any gasket material on joint surfaces.

- Use copper conductors only for supply wires. Refer to nameplate and Table B for size and rating required.
- Connect supply line ground conductor to the box lug provided on the base plate below contactor input lugs.

Table B – Supply Wiring Requirements

Model	kW	Phase	Volts	Supply Wire		Wiring Diagram #
				90°C Size (ga)	Max Fuse Amps	
CXH-A-03	3	1	208	10	25	I
CXH-A-03	3	3	208	12	15	II
CXH-A-03	3	1	240	10	20	I
CXH-A-03	3	3	240	12	15	II
CXH-A-03	3	3	480	12	15	II
CXH-A-03	3	3	575	12	15	II
CXH-A-05	5	1	208	8	35	I
CXH-A-05	5	3	208	10	20	II
CXH-A-05	5	1	240	8	30	I
CXH-A-05	5	3	240	10	20	II
CXH-A-05	5	3	480	12	15	II
CXH-A-05	5	3	575	12	15	II
CXH-A-07	7.5	1	208	6	50	I
CXH-A-07	7.5	3	208	8	30	II
CXH-A-07	7.5	1	240	6	45	I
CXH-A-07	7.5	3	240	8	25	II
CXH-A-07	7.5	3	480	12	15	II
CXH-A-07	7.5	3	575	12	15	II
CXH-A-10	10	3	208	8	40	II
CXH-A-10	10	1	240	4	60	I
CXH-A-10	10	3	240	8	35	II
CXH-A-10	10	3	480	10	20	II
CXH-A-10	10	3	575	12	15	II
CXH-A-15	15	3	208	4	60	II
CXH-A-15	15	3	240	6	50	II
CXH-A-15	15	3	480	8	25	II
CXH-A-15	15	3	575	10	20	II
CXH-A-18	18	3	240	4	60	II
CXH-A-20	20	3	480	8	35	II
CXH-A-20	20	3	575	8	30	II
CXH-A-25	25	3	480	8	40	II
CXH-A-25	25	3	575	8	35	II
CXH-A-30	30	3	480	6	50	II
CXH-A-30	30	3	575	8	40	II
CXH-A-35	35	3	480	4	60	II
CXH-A-35	35	3	575	6	50	II

- The fan motor is factory wired at the same voltage, and phase as the heating elements. All motors are thermally protected and connected to the main supply contactor. On three phase units, it is necessary to verify that the fan rotation is correct. Air stream discharge must be out front of unit. After connecting unit to line and closing all covers tightly, energize unit momentarily. If air does not exit front louvers, reverse any two supply leads at the box lugs on the contactor or at the supply disconnect.
- Either of two 1 NPT rigid conduit openings with integral stops may be used for connection to supply line. (See Figure 9 and 10 for locations) Use only NEC approval hazardous locations means of wiring such as mineral insulated cable and fittings or rigid conduit and seal fittings located as required by installation codes.

⚠ WARNING

EXPLOSION HAZARD. All unused conduit openings must be fitted with plugs that are U.L. recognized for use in hazardous locations.

- Heaters may be provided with a built-in control switch and/or thermostat. If not, they should be controlled by an externally mounted disconnect switch and/or separately mounted thermostat as shown in the appropriate wiring diagram on page 6. In case of malfunction, the personnel in the area should be aware of location of heater disconnect.
- Installation must include appropriate over current protection devices (fusing or circuit breakers) as required by the National Electric Code in the supply line to the unit. Refer to nameplate for proper current ratings.
- To operate heaters from an externally mounted hazardous location thermostat, a terminal block is provided for connection (Figures 9 and 10). Remove the factory installed jumper across T2 and T3 on the terminal strip. Wire the thermostat contact leads to these terminals. The built in control transformer supplies the unit with either 24V or 120V for internal unit operation. This voltage will appear across the thermostat contacts when they are open. The minimum thermostat contact rating should be 1 amp @ 120 VAC. Refer to nameplate for control voltage of unit. The 1/2 NPT conduit wiring entry on top of the terminal enclosure should be used to wire the thermostat to the heater (Figure 10).
- Protection against overheating is provided by a manual reset limit control located within the heat exchanger wiring compartment. (Figure 9) Activation of the control will open the control circuit and energize the pilot lamp (if supplied). If normal airflow is restricted, or stopped, the unit will be cycled off by the manual reset cutout. The manual reset limit control is also designed to shut down the unit completely if the fluid level is low or other heater malfunction occurs.

⚠ WARNING

Manual reset limit control must never be bypassed in the control circuit. If the limit actuates, shut down unit and investigate cause of abnormal operation. Do not reenergize until the problem has been corrected.

⚠ WARNING

Users should install adequate back-up controls and safety devices with their electric heating equipment. If the back-up controls are to be located in the hazardous area, they must be approved for use in the class of location. Where the consequences of failure may be severe, back-up controls are essential.

WIRING DIAGRAMS

DIAGRAM I

Refer to Name Plate for Input Voltage

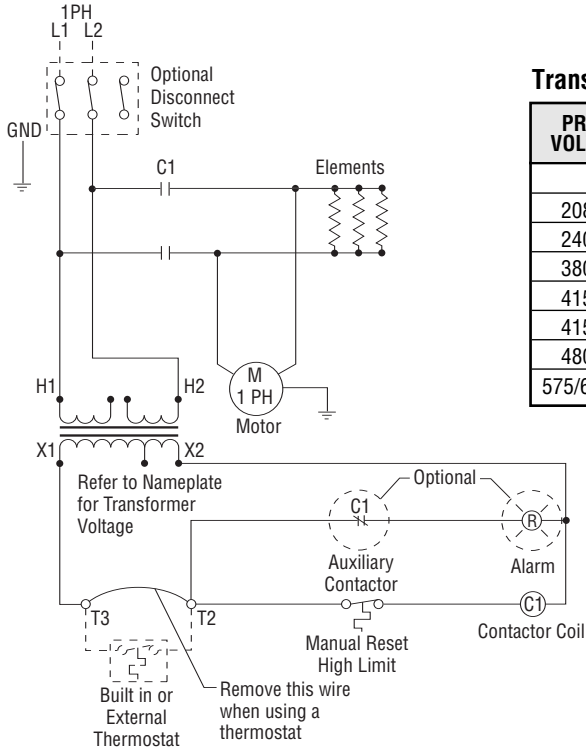

Transformer Color Code Tabulation

PRI VOLT.	PRI. XFMR LEAD CLRS.		120V SEC LEAD CLRS.		24V SEC LEAD CLRS.	
	H1	H2	X1	X2	X1	X2
208	BLK	RED	BLK	WHT	YEL	BLU
240	BLK	ORG	BLK	WHT	YEL	BLU
380	BLK	VIO	BLK	WHT	YEL	BLU
415	BLK	YEL	BLK	WHT	-	-
415	BLK	BRN	-	-	YEL	BLU
480	BLK	BLK/RED	BLK	WHT	YEL	BLU
575/600	BLK	GRY	BLK	WHT	YEL	BLU

— Factory Wiring
 - - - - - Optional or Customer Wiring

DIAGRAM II

Refer to Name Plate for Input Voltage

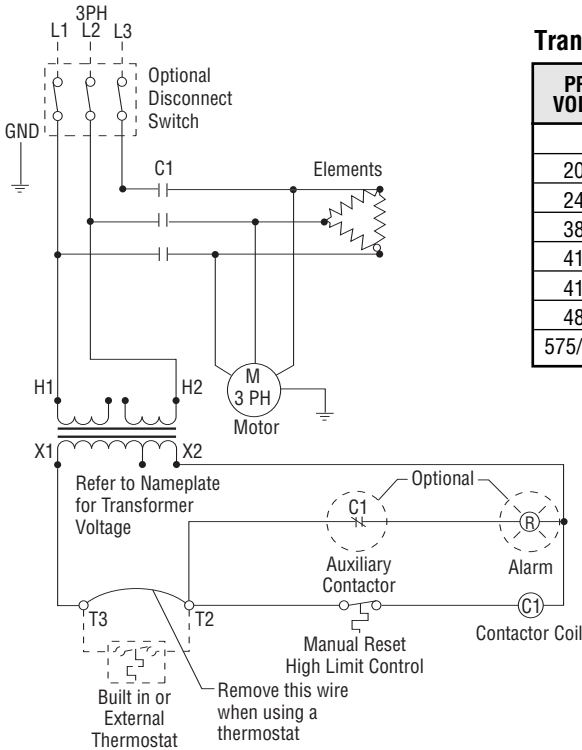

Transformer Color Code Tabulation

PRI VOLT.	PRI. XFMR LEAD CLRS.		120V SEC LEAD CLRS.		24V SEC LEAD CLRS.	
	H1	H2	X1	X2	X1	X2
208	BLK	RED	BLK	WHT	YEL	BLU
240	BLK	ORG	BLK	WHT	YEL	BLU
380	BLK	VIO	BLK	WHT	YEL	BLU
415	BLK	YEL	BLK	WHT	-	-
415	BLK	BRN	-	-	YEL	BLU
480	BLK	BLK/RED	BLK	WHT	YEL	BLU
575/600	BLK	GRY	BLK	WHT	YEL	BLU

— Factory Wiring
 - - - - - Optional or Customer Wirir

MODEL NUMBER DESCRIPTION							
CXH-A	10	4	3	30	40	1	1 EP
		Heater Voltage			30 = 24V Controls 32 = 120V Controls	1 = Ethylene Group C & D, E, F, G T3B 2 = Propylene Group C & D, E, F, G T3B 3 = Ethylene Group C, D, F, G T3B 4 = Propylene Group C, D, F, G T3B	Explosion Proof
		2 = 240V 6 = 575V 3 = 380V 8 = 208V 4 = 480V 9 = 600V 5 = 415V					0 = No Options 1 = 15 or 30 Amp Disconn. Switch 2 = 60 Amp Disconn. Switch 3 = Pilot Light 4 = Pilot Light and 30 Amp Disconn. Switch 5 = Pilot Light and 60 Amp Disconn. Switch 6 = Summer Fan Switch 7 = Summer Fan Switch, Pilot Light 8 = Disconn. Switch with Summer Fan Switch 9 = Disconn. Switch, Pilot Light with Summer Fan Switch
		Heating Element Rating	Phase			00 = No Thermostat 40 = Thermostat	
		03 = 3.0 kW 18 = 18.0 kW 05 = 5.0 kW 20 = 20.0 kW 07 = 7.5 kW 25 = 25.0 kW 10 = 10.0 kW 30 = 30.0 kW 15 = 15.0 kW 35 = 35.0 kW	1 = 1 Phase 3 = 3 Phase				
Electric Blower Unit Heater for Hazardous Locations							

OPERATION

⚠ WARNING

EXPLOSION HAZARD. Heater should not be operated in ambient temperature higher than 40°C (104°F) or in atmospheres corrosive to the heater itself.

- The CXH-A unit heaters use a sealed water-glycol filled heat exchanger. The electric immersion elements transfer heat energy directly to the fluid generating a fluid/vapor mixture which releases its heat energy to the finned radiator as it rises and recondenses back to the bottom reservoir to be reheated. This cycle will continue as long as fan forced air is available on the finned structure to remove the heat to the airstream.

- The finned structure of the heat exchanger must be kept clean and free of accumulated dust and dirt. The cabinet front panel is easily removed providing access to the heater core for periodic cleaning.
- Unit should not be operated with louvers fully closed. Mechanical stops are incorporated into the design of the cabinet to limit the degree of closure. Do not force the louvers beyond these stops.
- If specified, units are supplied with a built in alarm pilot lamp which will energize if the manual reset control has been activated. During unit startup, the lamp will flash on momentarily to verify its operation.

MAINTENANCE AND REPAIR

Maintenance and repair must be performed by qualified personnel only.

⚠ WARNING

EXPLOSION/ELECTRIC SHOCK HAZARD. Disconnect all power before opening enclosure covers or servicing heater. Failure to comply could result in personal injury or property damage.

- Periodically inspect all electrical connections and terminals to avoid electrical wiring difficulties. Inspect all wiring for frayed or worn insulation.
- Periodically and before each heating season, clean the finned heat exchanger and fan inlet with compressed air, vacuum, or water jet. Be sure all electrical covers are tightly closed.
- If heat output seems to be low, check amperage draw on each element. Compare measured values to the correct currents as listed on the unit nameplate.
- The thermally protected fan motor is permanently lubricated and sealed. No field servicing is required or should be attempted. Replace only with a factory supplied identical motor. Failure to do so will void the factory warranty and may expose the user to risk of ignition of hazardous atmospheres.
- Check fan blade to be sure that set screws are tight and there are no cracks or looseness in the blades. Use factory supplied replacement blade only.
- Check for any sign of leaking from the heat exchanger. Too little fluid will cause the manual high limit to trip.
- The sealed heat exchanger contains a glycol/water solution of propylene glycol. Ethylene glycol is supplied for arctic duty conditions only. Avoid contact with skin and eyes. If ingestion should occur, seek medical attention immediately. In case of eyes or skin contact, wash affected areas with large amounts of water. The MSDS (Material Safety Data Sheet) for these materials is available upon request.

I. REPLACING THE HEAT EXCHANGER

⚠ CAUTION

BURN HAZARD. Be sure heat exchanger and fluid has been allowed to cool to 110°F before proceeding.

- Detach the cabinet front by removing screws from all sides of unit and pulling cover forward off cabinet shell. Detach bottom panel by removing two screws on each side and two screws in the rear. Remove the electrical control enclosure lid. Disconnect the heater and high limit wires from the electrical control enclosure. Loosen electrical conduit union located between the heater housing and the electrical control enclosure. Support the lower end of the heat exchanger and loosen the three hex head bolts which hold it to the sheet metal. Lower the heat exchanger away from the sheet metal. Reverse the above procedure when installing a new heat exchanger.

II. RESETTING MANUAL RESET LIMIT CONTROL

⚠ WARNING

EXPLOSION HAZARD. Be sure that all enclosure covers are replaced and tightly closed before re-energizing unit after servicing electrical components.

High limit controls must never be bypassed in control circuit.

The factory must perform the replacement of the immersion heater or overtemperature cutout. The heat exchanger seal must not be broken. Consult factory for service.

MAINTENANCE AND REPAIR

The occurrence of the manual reset limit control to trip is an abnormal condition. Care should be taken to determine the exact reason that the high limit control tripped. Possible problem areas could be dirty heat exchanger, blocked air inlet or outlet, fan/motor malfunction, too high operating ambient, incorrect operating voltage, or leaking heat exchanger. In the event that the heat exchanger is defective, it must be replaced.

1. The manual reset limit control is located in the heating element hazardous location enclosure on the heat exchanger which is covered by the sheet metal housing attached to the side of the unit. To gain access, remove the four sheet metal screws holding the sheet metal cover in place and unthread the cast aluminum enclosure lid. (See Figure 11.) The manual reset limit control device has a small reset button protruding from the center of its back housing. Depress this button in to reset the control. Replace the aluminum enclosure lid and sheet metal cover.

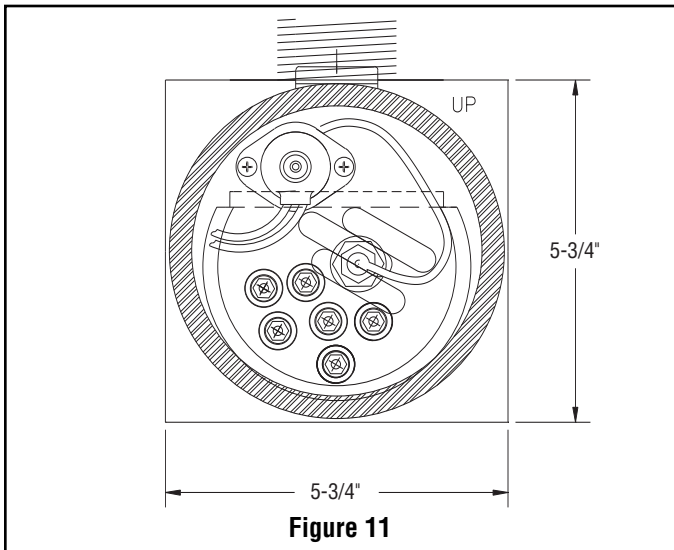

Figure 11

III. FAN MOTOR AND BLADE

1. The motor is a sealed unit that requires no lubrication. If the motor is defective, it must be replaced with an original factory supplied motor. (See renewal parts section.)
2. To replace the motor, proceed as follows:
 - A. Disconnect the unit from power supply.
 - B. (Units with motor splice box) Remove 4 bolts and cover of motor splice box (See Figure 12).
 - C. (Units without motor splice box) Remove 16 bolts and cover of main control enclosure.
 - D. Note wire connections for future reference and disconnect all wires leading to the motor. All motor wires are permanently marked according to the nameplate on the motor.

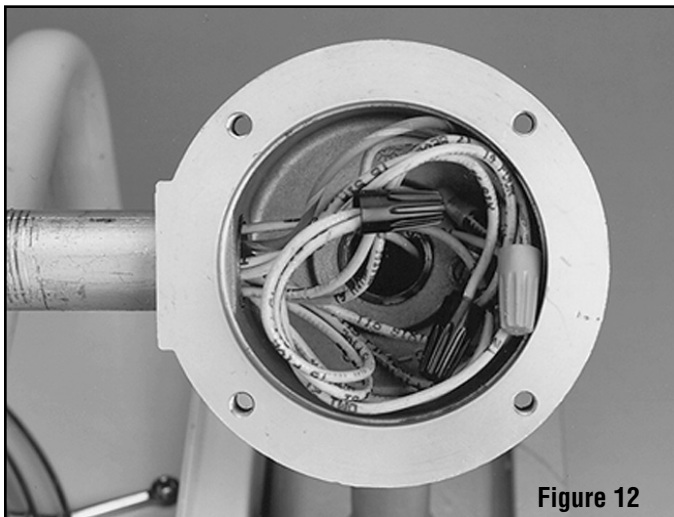

Figure 12

- E. Remove 4 bolts in motor base holding it to rear cabinet shelf. See Figure 13.
- F. Remove 4 screws holding fan guard to cabinet.

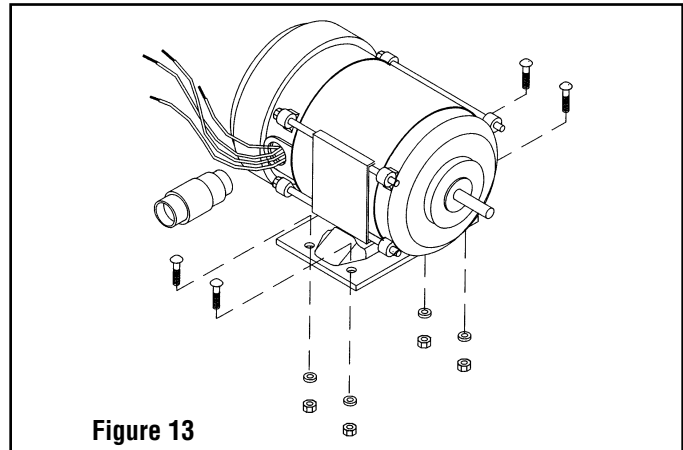

Figure 13

- G. Unthread union at motor wiring outlet nipple connection. Carefully lift the motor, fan blade, and guard off of the cabinet.
 - H. Note position of fan blade on motor shaft. Loosen the two set screws to remove the fan blade and key from shaft.
 - I. Place guard and fan blade on replacement motor shaft in same locations as original motor. Align key ways in hub and shaft. Insert key flush with fan hub and tighten the two hub set screws.
 - J. Feed motor wires back into conduit and reposition motor back on unit. Center fan blade in opening and rotate to be sure that it clears housing and guard.
 - K. Thread motor nipple connection into conduit union and tighten (5 threads minimum). Replace bolts in motor base and reattach fan guard to back of housing in four places. Recheck blade rotation and tighten all hardware.
 - L. Trim all motor leads extending out of the conduit to 6 lengths. Strip off 3/8 of insulation at cut ends. Using the motor nameplate, previous notes, and marked wires, reconnect the motor for the unit voltage rating as indicated on the heater nameplate. Re-attach the ground wire to the connection inside the enclosure. Replace cover and tighten securely.
 - M. Check fan rotation by momentarily energizing the unit. Air must exit at cabinet front. Reverse any 2 leads at contactor or line supply disconnect to reverse rotation of three phase motor.
3. Removal of fan blade does not require that the motor wiring be disturbed. To clean, service or change the fan blade proceed as follows:
 - A. Remove the four carriage bolts holding the motor base in place on the cabinet platform. Mark the platform to reposition at same location.
 - B. Loosen the four screws on the cabinet back holding the fan guard in place.
 - C. Pull the motor to the rear extending the conduit connection at the electrical enclosure. Fan blade and hub set screws can now be accessed by tilting the guard rearward at top or bottom back over the motor shell.

IV. ELECTRICAL COMPONENT SERVICING

⚠ WARNING

EXPLOSION/ELECTRIC SHOCK HAZARD. Disconnect all power before opening enclosure covers or servicing heater. Failure to comply could result in personal injury or property damage.

When provided, the following components are located in the cast aluminum hazardous location enclosure. Remove cover and retaining bolts to gain access the following items (See Figure 16):

MAINTENANCE AND REPAIR

1. CONTROL TRANSFORMER

This item is located in the electrical enclosure. It may be replaced while in the enclosure. To service or replace remove the quick connect wires and mark their locations. Remove two screws which hold the transformer in place. Note transformer orientation and voltage labels on top. Replace transformer in the same orientation and connect wires. Replace the cast aluminum cover and bolt down.

2. CONTACTOR

This component can be removed from the base plate while in the enclosure. Follow the same steps as indicated for the transformer replacement.

3. ALARM PILOT LAMP (OPTIONAL)

To replace the bulb, unscrew the red lens bezel while holding the lock ring until disengaged. Avoid turning the entire assembly

which is held tight to the enclosure with a locking nut on the inside of the enclosure. It must be re-tightened if loosened before reuse. Replace the lamp with a 656 type bulb at the correct control voltage for the unit (120V or 24). Secure the lens cap (5 threads minimum) against the locking ring and tighten securely before re-energizing unit. Lamp should flash on momentarily when unit is energized. See renewal parts section for part number of replacement bulbs.

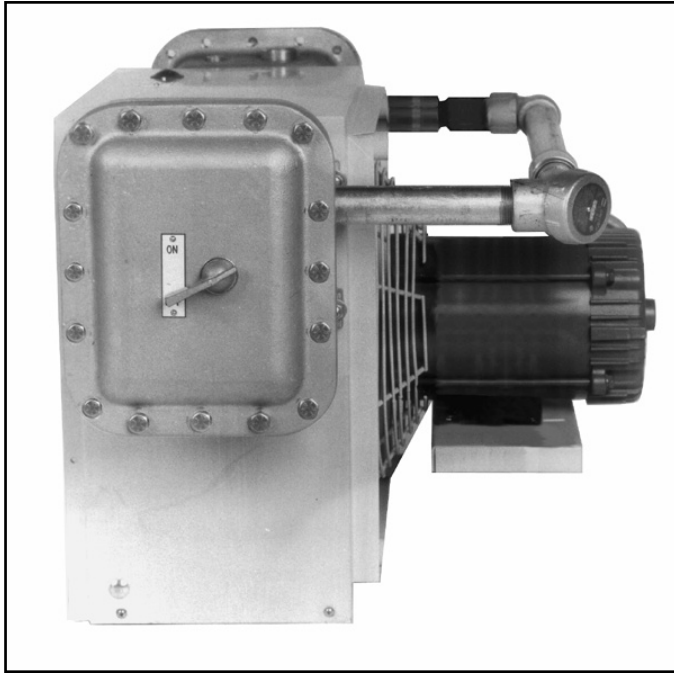

Figure 14
CXH-A with Built in Disconnect Switch
(Must use HMK-00 Ceiling Mounting Kit)



Figure 15
CXH-A with Built in Thermostat

RENEWAL PARTS IDENTIFICATION

Publication Number	Title
PF458	Mounting Kits for Model CXH-EP
PF461	Material Safety Data Sheet Chromakool EG
PF462	Material Safety Data Sheet Chromakool PG

RENEWAL PARTS IDENTIFICATION

Electrical Control Voltage	24V	120V
Contactors	072-304551-002	072-304551-008
Transformer 208/240/480 PRI	315-304252-002	315-304252-001
Transformer 575 PRI	315-304252-005	315-304252-003
Aux. Contactors	072-304551-102	072-304551-102
Transformer 380/415 PRI	315-304252-006	315-304252-007
Transformer CXH-B	—	315-304252-008

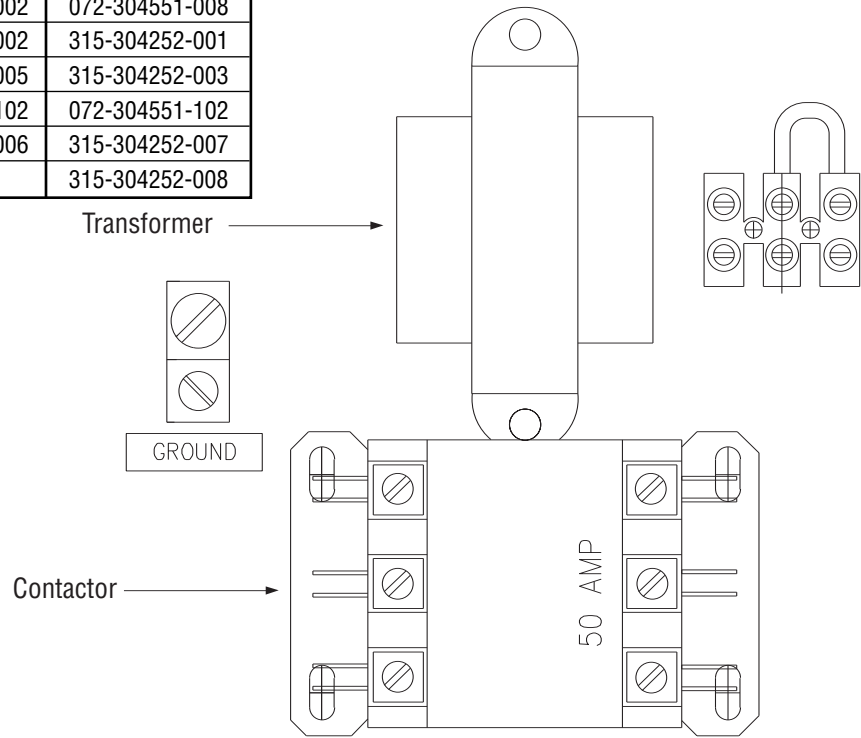

Figure 16

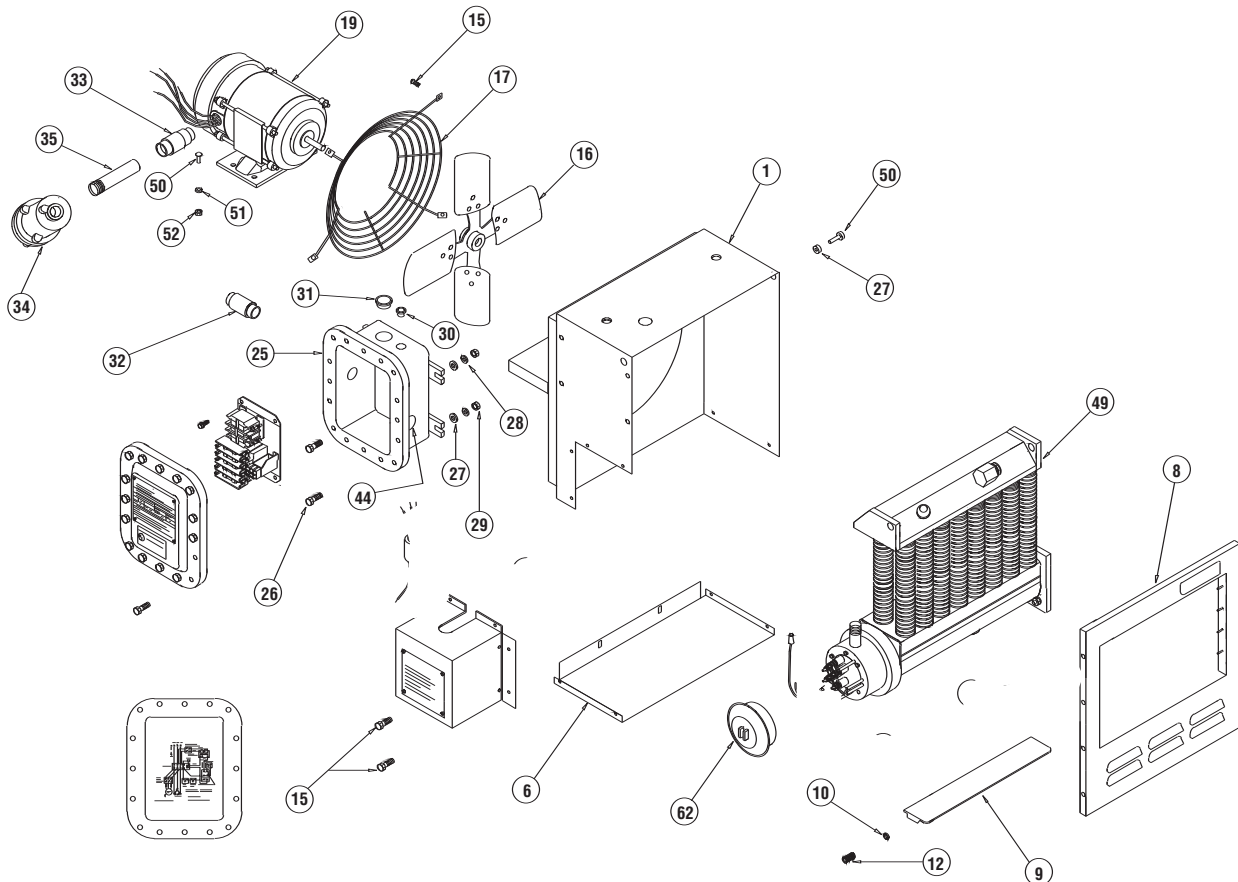
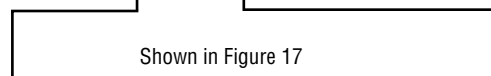

Figure 17

**MANUFACTURER PART NUMBER BREAKDOWN
(LOCATED ON UNIT NAMEPLATE)**

CXH-A-□□ - □□ - □□ - EP



Common Parts

Shown in Figure 17

Motor, Element and Heat Exchanger Parts

Item#	Description	Code CXH-A-03 05, 07 & 10 Part No.	CXH-A-15, 18 & 20 Part No.	CXH-A-25, 30 & 35 Part No.
1	Panel wrapper	207-303891-001	207-303891-002	207-303891-003
6	Panel Bottom	207-303881-001	207-303881-002	207-303881-003
8	Panel Front	207-303883-001	207-303883-002	207-303883-003
9	Louver	182-303884-001	182-303884-002	182-303884-003
10	Washer Shoulder	328-302074-002	328-302074-002	328-302074-002
12	Spring	276-130368-001	276-130368-001	276-130368-001
14	Terminal Box Cover	080-302079-001	080-302079-001	080-302079-001
15	Screw 10-32	248-073662-002	248-073662-002	248-073662-002
16	Fan Blade	Consult Factory	Consult Factory	Consult Factory
17	Fan Guard	134-302063-004	134-302063-005	134-302063-006
25	Enclosure	347-304561-001	347-304561-001	347-304561-001
26	Bolt 3/8-16, 1.5 lg	345-075603-263	345-075603-263	345-075603-263
27	Washer flat	328-075528-085	328-075528-085	328-075528-085
28	Washer lock	328-075571-011	328-075571-011	328-075571-011
29	Hex Nut 3/8-16	200-075473-044	200-075473-044	200-075473-044
30	Plug conduit 1/2"	221-302180-001	221-302180-001	221-302180-001
31	Plug conduit 1"	221-302180-003	221-302180-003	221-302180-003
32	Union conduit 3/4"	354-302165-001	354-302165-001	354-302165-001
33	Union conduit 3/4"	354-302243-001	354-302243-001	354-302243-001
34	Conduit Box	Consult factory	069-304115-002	069-304115-002
35	Conduit 3/4"	Consult factory	Consult factory	Consult factory
44	Plug conduit 3/4"	221-302180-002	221-302180-002	221-302180-002
50	Bolt 5/16-18	345-075603-218	345-075603-218	345-075603-218
51	Washer	328-075571-010	328-075571-010	328-075571-010
52	Nut 5/16-18	200-075473-039	200-075473-039	200-075473-039
62	Cover Exp. Proof	080-042350-007	080-042350-007	080-042350-007
75	Conduit 3/4"	069-115087-049	069-115087-079	069-115087-093

Model	1/4 HP Motor Item 19	Heat Exchanger* Item 49
CXH-A-03-81	193-302087-006	353-304167-001
CXH-A-03-83	193-302087-007	353-304167-001
CXH-A-03-21	193-302087-006	353-304167-002
CXH-A-03-23	193-302087-007	353-304167-002
CXH-A-03-43	193-302087-007	353-304167-005
CXH-A-03-63	193-302087-008	353-304167-006
CXH-A-05-81	193-302087-006	353-304167-008
CXH-A-05-83	193-302087-007	353-304167-008
CXH-A-05-21	193-302087-006	353-304167-009
CXH-A-05-23	193-302087-007	353-304167-009
CXH-A-05-43	193-302087-007	353-304167-012
CXH-A-05-63	193-302087-008	353-304167-013
CXH-A-07-81	193-302087-006	353-304168-001
CXH-A-07-83	193-302087-007	353-304168-001
CXH-A-07-21	193-302087-006	353-304168-002
CXH-A-07-23	193-302087-007	353-304168-002
CXH-A-07-43	193-302087-007	353-304168-005
CXH-A-07-63	193-302087-008	353-304168-006
CXH-A-10-83	193-302087-007	353-304168-008
CXH-A-10-21	193-302087-006	353-304168-009
CXH-A-10-23	193-302087-007	353-304168-009
CXH-A-10-43	193-302087-007	353-304168-012
CXH-A-10-63	193-302087-008	353-304168-013
CXH-A-15-83	193-302087-007	353-304169-001
CXH-A-15-23	193-302087-007	353-304169-002
CXH-A-15-43	193-302087-007	353-304169-005
CXH-A-15-63	193-302087-008	353-304169-006
CXH-A-18-23	193-302087-007	353-304169-008
CXH-A-20-43	193-302087-007	353-304169-012
CXH-A-20-63	193-302087-008	353-304169-013
	1/2 HP Motors	
CXH-A-25-43	193-302087-009	353-304170-003
CXH-A-25-63	193-302087-010	353-304170-004
CXH-A-30-43	193-302087-009	353-304170-008
CXH-A-30-63	193-302087-010	353-304170-009
CXH-A-35-43	193-302087-009	353-304170-012
CXH-A-35-63	193-302087-010	353-304170-013

* For arctic duty conditions, heat exchanger with ethylene glycol are required. Consult factory.

Optional Equipment Parts

Description	Part Number
Thermostat	300-113075-003
30 Amp Disconnect	104-304328-001
60 Amp Disconnect	104-304328-002
Pilot Light Ass'y 24V	213-121103-017
Pilot Light Ass'y 120V	213-121103-018
Pilot Lamp 24V	172-052561-004
Pilot Lamp 120V	172-052561-003

Mounting Kit Adapter

CXH-A-03 through 10	027-302361-001
CXH-A-15 through 20	027-302361-002
CXH-A-25 through 35	027-302361-003

⚠ WARNING

The factory must perform the replacement of the immersion heater or overtemperature cutout. The heat exchanger seal must not be broken. Consult factory for service.

Sales • Engineering

“Heat and Control
Specialists”



GORDO SALES, INC.

P.O. Box 1166 Layton, UT 84041
Phone: 801-544-4236 Fax: 888-264-0740
<http://www.gordosales.com>
lhuggins@gordosales.com

Limited Warranty:

Please refer to the Chromalox limited warranty applicable to this product at
<http://www.chromalox.com/customer-service/policies/termsofsale.aspx>.

Chromalox[®]
PRECISION HEAT AND CONTROL

2150 N. RULON WHITE BLVD., OGDEN, UT 84404
Phone: 1-800-368-2493 www.chromalox.com