

Standard Pump

Centrifugal Drum Pump Motor Models: SP-410EX, SP-420EX, SP-280P, SP-ENC, SP-A1 & SP-A2

Description

Standard's Drum Pumps are designed to transfer a variety of materials from 55 gallon drums and tanks. Standard Pump offers several different pumps, each designed for specific applications. Before operating, please confirm that the pump's materials of construction are suitable for the application.

Unpacking

Cartons should be handled with care to avoid damage from dropping, etc. After unpacking, inspect carefully for any damage that may have occurred during transit. Check for loose, damaged or missing parts.

General Safety Information

The responsibility for safe assembly, installation, and operation ultimately rests with the operator. Read and understand ALL safety precautions and operating instructions before operation. Careless pump operation can result in serious injury.

1. Before operating the pump, read and understand these operating instructions.
2. The operator should wear suitable protective clothing including the following: face mask, safety shield or goggles, gloves, apron, and safety shoes.
3. Before operating, verify the materials being pumped are compatible with the pump's "wetted components."
4. All Federal, State, and local safety codes should be followed.

5. Verify that the motor voltage corresponds to proper electrical supply.
6. Before plugging motor into power supply, make sure the motor switch is in the OFF position. For Air Motors ensure inlet valve is closed before attaching air line.
7. Before operation, confirm all pump connections are properly tightened.
8. First pump clean water in order to familiarize yourself with the pump's operation, flow rate, discharge pressure and motor speed.
9. Before starting the pump, confirm the discharge hose is securely fastened to the receiving vessel in order to prevent splashing.
10. Never leave pump unattended during operation.
11. Do not submerge the motor in any liquid.
12. When finished using the pump, flush the pump by pumping water or an appropriate cleaning solution. Do not use flammable or combustible cleaning solutions.
13. Never carry the motor by the power cord.
14. Never store pump in container. Always rinse pump thoroughly and hang on wall bracket or ensure pump tube is stored in an upright and vertical position.

Assembly

1. Remove the pump and motor from packaging.
2. Inspect all contents for damage.
3. Couple the motor to the pump tube by using the Hand Wheel. (See figure 1).

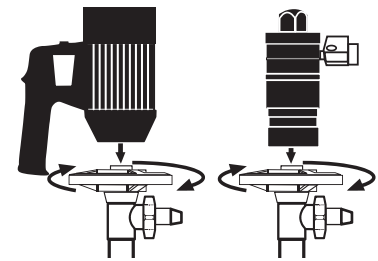

Figure 1

⚠ WARNING *The speed control switch should not be used as the main ON/OFF switch. Using the speed control switch in this manner causes excessive wear to the potentiometer and may result in premature failure. The use of the speed control switch does not cut power to the motor and inadvertent activation could result in injury or death if the motor is activated when not properly attended and secured. (Only applies to SP-280P and SP-ENC Series)*

Electric Drum Pump Motor Specifications

Model	Voltage	Amps	Watts	HP	Phase	Hz	Enclosure	Variable Speed	Hazardous Duty	Shipping Wt lbs (kg)
SP-410EX	115V	2	230	0.30	1	50-60	Hazardous Duty	N	Y	17 (7,7)
SP-420EX	230V	2.6	600	0.80	1	50-60	EXP (IP54)	N	AtEx	17 (7,7)
SP-280P	110V	8.5	825	1	1	50-60	ODP (IP44)	N	N	9.0 (4,0)
SP-280P-V	110V	8.5	825	1	1	50-60	ODP (IP44)	Y	N	9.0 (4,0)
SP-280P-2	220V	5	825	1	1	50-60	ODP (IP44)	N	N	9.0 (4,0)
SP-280P-2-V	220V	5	825	1	1	50-60	ODP (IP44)	Y	N	9.0 (4,0)
SP-ENC	110V	8.5	825	1	1	50-60	TEFC (IP54)	N	N	12.7 (5,7)
SP-ENC-V	110V	8.5	825	1	1	50-60	TEFC (IP54)	Y	N	12.7 (5,7)
SP-ENC-2	220V	5	825	1	1	50-60	TEFC (IP54)	N	N	12.7 (5,7)
SP-ENC-2-V	220V	5	825	1	1	50-60	TEFC (IP54)	Y	N	12.7 (5,7)

Centrifugal Drum Pump Motor Models: SP-410EX, SP-420EX, SP-280P, SP-ENC, SP-A1 & SP-A2

SP-280P & SP-ENC Spare Parts Lists

SP-280P See Figure 2

SP-ENC See Figure 3

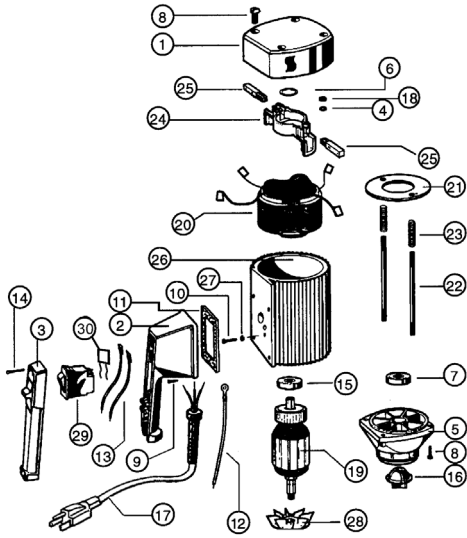

Figure 2 – SP-280P

Ref. #	Description	P/N for SP-280P	Qty
1	Motor Cover	8000	1
2	Switch Housing	8001	1
2A	Switch Housing for Variable Speed, Includes Potentiometer		
	110-120V	8004	1
	220-240V	8005	1
3	Switch Cover	8002	1
4	Lock Washer	8071	2
5	Lower Housing	8100	1
6	Wave Washer	8125	1
7	Ball Bearing	8126	1
8	Screw for Plastic Housing	8130P	8
9A	Screw, 110-120V	8131	4
9B	220-240V	8131LVR	4
10	Ground Screw	8162	1
11	Gasket, 110-120V	8167	1
	220-240V	8167LVR	1
12	Earthing Lead	8183	1
13	Lead	8185	2
14	Screw	8220	5
15	Ball Bearing	8331	1
16	Motor Coupling	8333	1
17	Power Cord w/Strain Relief & Plug		
	110-120V	8360	1
	220-240V	8705	1
18	Hexagon Nut	8448	2
19	Armature, 110-120V	8502	1
	220-240V	8701	1
20	Stator, 110-120V	8503	1
	220-240V	8502	1
21	Guide Disc	8504	1
22	Rod Connector	8506	2
23	Pressure Spring	8507	2
24	Brush Holder	8508	1
25	Carbon Brush, 110-120V	8509	2
	220-240V	8703	2
26	Motor Housing, Plastic	8510P	1
27	Star Washer	8511	1
28	Fan	8512	1
29	Overload Switch, 8.5 amp 110-120V	8611	1
	5 amp 220-240V Low Voltage Release	8704LVR	1
30	EMI Filter	8003	1
31	Repair Kit 110-120V (includes PN's 8333 & (2) 8509)	9055	1
32	Repair Kit 220-240V (includes PN's 8333 & (2) 8703)	9056	1

Ref. #	Description	P/N for SP-ENC	Qty
1	Motor Cover	3000	1
2	Screw	3130	1
3	Armature, 110-120V	3502	1
	220-240V	3701	1
4	Stator, 110-120V	3503	1
	220-240V	3702	1
5	Guide Disc	3504	1
6	Motor Housing	3510	1
7	Bearing Cover	3511	1
8	Fan	3512	1
9	Switch Housing	8001	1
9A	Switch Housing for Variable speed, Includes Potentiometer		
	110-120V	8004	1
	220-240V	8005	1
10	Switch Cover	8002	1
11	Lock Washer	8071	2
12	Lower Housing	8100	1
13	Wave Washer	8125	1
14	Ball Bearing	8126	1
15	Screw	8130	4
16A	Screw, 110-120V	8131	4
16B	220-240V	8131LVR	4
17	Ground Screw	8162	1
18	Gasket, 110-120V	8167	1
	220-240V	8167LVR	1
19	Earthing Lead	8185	1
20	Lead	8183	2
21	Screw	8220	5
22	Ball Bearing	8331	1
23	Motor Coupling	8333	1
24	Power Cord w/Strain Relief & Plug,		
	110-120V	8360	
	220-240V	8705	1
25	Hexagon Nut	8448	2
26	Rod Connector	3703	2
27	Brush Holder	8508	1
28	Carbon Brush, 110-120V	8509	2
	220-240V	8703	2
29	Star Washer	8511	1
30	Overload Switch, 8.5 amp 110-120V	8611	1
	5 amp 220-240V Low Voltage Release	8704LVR	1
31	EMI Filter	8003	1
32	Repair Kit 110-120V (includes PN's 8333 & (2) 8509)	9055	1
33	Repair Kit 220-240V (includes PN's 8333 & (2) 8703)	9056	1

SP-280P & SP-ENC Series motors should not be used to pump flammables.

Centrifugal Drum Pump Motor Models: SP-410EX, SP-420EX, SP-280P, SP-ENC, SP-A1 & SP-A2

Air Drum Pump Motor Specifications

Model	HP	Watts	Max Inlet Pressure	Min Hose	Max dBA	Airline Size Inches	Hazardous Duty	Air Consumption	Shipping Wt lbs (kg)
SP-A1	1/2	370	100 psi(6,8 bar)	3/8"(10 mm)	109.50	1/8" NPT	AtEx	22 CFM (10,4 L/sec)@ 90 PSI (6,2 Bar)	2.7 (1,2)
SP-A2	3/4	560	100 psi(6,8 bar)	3/8"(10 mm)	109.50	1/4" NPT	Y	28 CFM (13,2 L/sec)@ 90 PSI (6,2 Bar)	3.4 (1,5)
SP-A2TL (Trigger Lock)	3/4	560	100 psi(6,8 bar)	3/8"(10 mm)	109.50	1/4" NPT	Y	28 CFM (13,2 L/sec)@ 90 PSI (6,2 Bar)	3.4 (1,5)

SP-A1 & SP-A2 Spare Parts Lists

SP-A1 See Figure 4

Ref. #	Description	P/N for SP-A1	Qty
1	Muffler	SAF350	1
2*	Gasket	SAC229	1
3	Dead end cap	SAC228A	1
4*	Bearing	SAG549	2
5	Dead end plate	SAC617	1
6*	Gasket	SAC527	2
7	Body	SAE899	1
8	Drive end plate	SAC616	1
9*	Shaft seal	SAC190A	1
10*	Vane	SAE893	4
11	Dowel pin	SD324A	4
12	Impeller	SAE896	
13	Repair kit*	SK285	1
	Includes item numbers		1
	2, 4, 6, 9 and 10		1
14	A1 adapter	9007	1

SP-A2 See Figure 5

Ref. #	Description	P/N for SP-A1	Qty
1	Housing Assembly	317A-A40	1
2*	Inlet Bushing (with Screen)	317A-3B	1
3	Trigger Assembly	317A-A93	1
4*	Regulator Assembly	317A-A249	1
5	Muffler Kit	317A-AMK1	1
6*	Rear-End Plate Assembly	317A-A12	1
7	Cylinder	317A-3	1
8	Vanes (Set of 4)	317A-42-4	4
9*	Rotor	317A-53	1
10*	Front-End Plate, Assembly	317A-A11	1
11	Motor Lock-Nut	317A-27	1
12	Motor Coupling	8333	1
13	Adaptor, Aluminum	9014	1

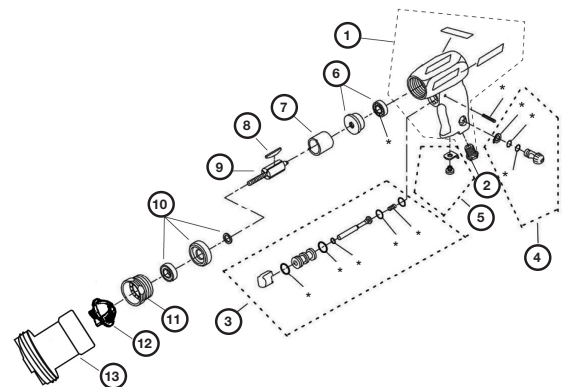
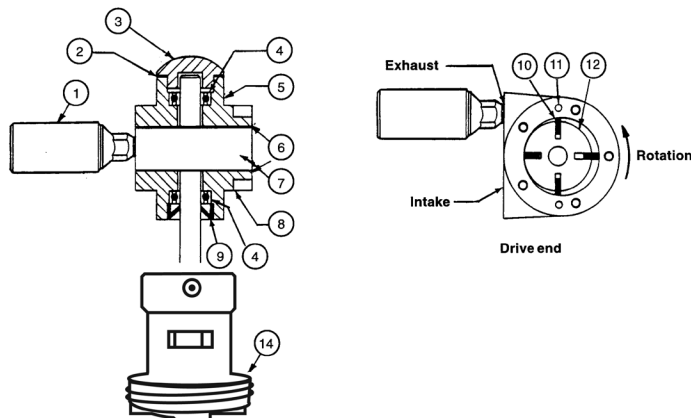

Figure 4 – SP-A1

Figure 5 – SP-A2

Centrifugal Drum Pump Motor Models: SP-410EX, SP-420EX, SP-280P, SP-ENC, SP-A1 & SP-A2

Hazardous Duty Operation

▲ WARNING *When pumping flammable or combustible products or operating in a hazardous duty environment, the SP-8600, SP-8700, SP-8800, SP-8900, SP-AL or SP-SS Series pump must be used in conjunction with an explosion proof motor. Please contact the factory or an authorized distributor with any questions regarding this matter.*

SP-420 EX & SP-A1 Series

When operating in Hazardous Duty applications SP-420EX or SP-A1 must be used in conjunction with an SP-SS, SP-AL, SP-8600 or SP-8800 Series pump and properly bonded and grounded. Refer to the Motor specification chart for motor information.

Special Conditions for Safety Use

- Only for conductive liquids (gases groups IIA and IIB).
- The flashpoint for the flammable media shall be 50°C higher than the maximum temperature T4 (135°C).
- The SP-AL versions may not be used in an area where rusty particles or rusty iron is present.
- The tube shall regular be inspected for damage and corrosions. If there is any damage or corrosions the equipment and the tube shall be taken out of service.
- The grounding clamp and wire on the pump shall be connected to the liquid container before and after pump start.
- The pumps must not be exposed to pumping hard solid particles which can create sparks.
- Demands for inspections, maintenance and repair according to the instructions.
- The pump is only for hand held operation and may not be running dry.
- The SP-AL version may only be used with the PTFE impeller parts no. 2706 and 4608HH.

Drum Pump Installation

SP-410EX

- Install the Pump and Static Protection Kit as described in Figure 2 on page 7.
- Connect Ground Wire assembly to earth ground using supplied clamp.
- Connect Ground Wire between drum and earth ground.
- Connect Ground Wire between receiving container and earth ground (or use bonding wire to connect to drum).

▲ CAUTION *Check electrical continuity of all components before pumping. All should be one (1) ohm or less.*

Operation and Safety Guidelines

- Use only metallic pump tubes with explosion proof motors to transfer flammable or combustible liquids.
- Area for use must comply with NFPA 30 guidelines for safe storage and use of flammable and combustible liquids.
- All containers and other equipment must be metal and grounded.
- Follow NGPA 77 guidelines for control of static electricity.
- Avoid splashing. Splash filling can create static electricity and is extremely hazardous.
- Fluid velocity must be 3 feet/second (0.91 meters/second) maximum 7 GPM in 1" hose (26.5 LPM in 25 mm hose).

Use Of Air Motors In Hazardous Atmospheres SP-A1 Series & SP-A2 Series

At the present time, there are no known standards governing the operation of air motors in hazardous atmospheres. However, there are several points regarding the safety of air motors.

First of all, an air motor is not a source of electric sparks. However, it is possible that an article which is not part of the air motor (e.g., wrenches, hammers, etc.) could create a spark by sharply impacting a cast iron or aluminum case or the steel shaft of the air motor. (Note that electric motor enclosures

for both class I and II hazardous locations can be made of "...iron, steel, copper, bronze, or aluminum..." (UL 674, Electric Motors and Generators – Hazardous Locations, June 23, 1989; paragraph 4.2, page 6). Second, an air motor housing is not designed to contain an internal explosion as is an explosion-proof electric motor. The only possible internal source of ignition in an air motor is a contact between the station housing components and the rotating elements that might create a spark. The likelihood of this occurring is reduced by the fact that the contact must be made at precisely the same time as a flammable or explosive gas is introduced into the air motor in a sufficient quantity to achieve a flammable or explosive mixture while overcoming the positive pressure of the driving gas. In other words, although highly improbable, an internal explosion in an air motor is possible. Finally, an air motor is designed to be operated by compressed air, the expansion of which in normal operation creates a cooling effect. As a result, the temperature of the air motor will not exceed the height of the temperatures of the surrounding atmosphere or the air delivered to the inlet.

We do not guarantee the safety of every application, but to ensure the safe operation of an air motor in your application, always follow the product direction and consult with a qualified engineer. (Source: Gast Manufacturing, Air Motors Handbook, page 2) Note: This statement is only applicable in North America.

▲ WARNING *When using an SP-A1 or SP-A2 Series motor, Standard Pump recommends the use of a Filter Lubricator Regulator (FLR) in order to ensure a moisture free supply of air to the motor.*

▲ WARNING *SP-A1 and SP-A2 Series motors must be lubricated daily to ensure proper functionality*

**Centrifugal Drum Pump Motor Models:
SP-410EX, SP-420EX, SP-280P, SP-ENC, SP-A1 & SP-A2**

Grounding Procedures

⚠ WARNING *Transferring of flammables or use in hazardous duty. Bonding is an electrical connection between a primary metal vessel and a metal receiving vessel. See schematic.*

Grounding is an electrical connection between a metal vessel, pump, motor and a constant ground; i.e. a metal rod driven into the earth.

Bonding and grounding are required when pumping flammable materials or in hazardous duty environments. Failure to bond and ground properly can cause a discharge of static electricity resulting in fire, injury or death. Follow NFPA 77 and 30 procedures at all times. If in doubt, do not start pump! Be sure bonding and grounding wires are secure before starting operation. (Ground and bond wires must have less than one ohm resistance for safe usage. Check continuity

before starting). Always check with a safety engineer when any question arises and periodically check safety procedures with a safety engineer.

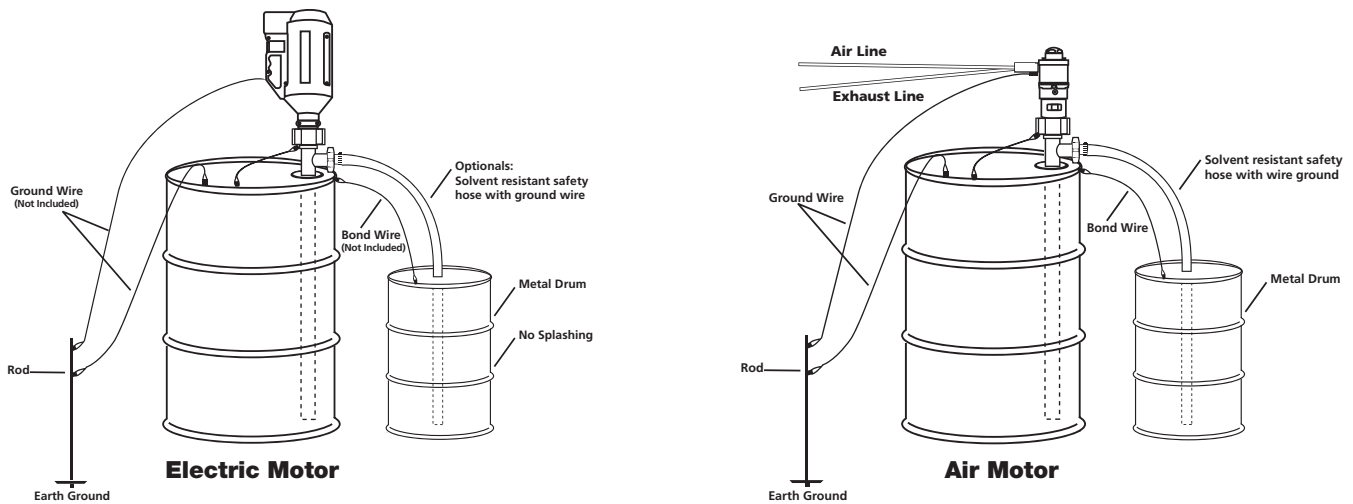

Figure 6 - Static Protection Kit

Centrifugal Drum Pump Motor Models:

SP-410EX, SP-420EX, SP-280P, SP-ENC, SP-A1 & SP-A2

STANDARD PUMP
Europe

Standard Pump Europe A/S
Volundsvej 12
DK-3400 Hillerød
Denmark
Phone: + 45 70 23 21 00
Fax: + 45 70 23 56 55
info@standard-europe.eu

EC-Conformity Declaration
ATEX 94/9/EC

We herewith declare that the under mentioned products:

Model name: SP-SS/HH, SP-AL, SP-8600/8700 and SP-8800/8900
Model design: All versions

Technical data: Equipment group II, Category 2G and 3G
Marking: EX II 2G c IIB T4
Liquid temperature: Max. 40°C
Ambient temperature: +5°C to +40°C

Confirms with the relevant EC Directive: Directive 94/9/EC for equipment and protective systems intended for use in potentially explosive atmospheres (ATEX).

Applied harmonized standards: EN 13463-1:2009
EN 13463-5:2003

In accordance with appendix VII of 94/9/EC the documents are stored by the notified body:

Danish Technological Institute
Kongsvang Alle' 29
DK-8000 Århus C
Certificate no.: DTI 13.0022X

The protection of the pump against abnormal working situations has to be insured by user.

Hillerød, April 4th. 2013

Standard Pump Europe A/S

Hans-Peder Jensen
Technical Director

Warranty

Declarations

Declaration of Conformity	When this unit is used as a stand alone unit it complies with: Machinery Directive 98/37/EC EN60204, EN60335-2-41, EN60335-1, Low Voltage Directive 73/23/Eec EN61010-1, EMC Directive 89/336/Eec EN55014, EN 550104, EN50081-1, EN50082-1
Declaration of Incorporation	When this pump unit is to be installed into machine or is to be assembled with other machines for installations, it must not be put into service until the relevant machinery has been declared in conformity with Machine Directive 98/37/EC EN60204, EN60335-2-41, EN60335-1.

Responsible person: Donald M. Murphy, President, Standard Pump, Inc.
1540 University Drive, Auburn, Georgia 30011
Ph: 001-770-307-1003 Fax: 001-770-307-1009
e-mail: info@standardpump.com
www.standardpump.com

Three year limited warranty

Standard Pump, Inc. warrants, subject to the conditions below, through either Standard Pump, Inc., its subsidiaries, or its authorized distributors, to repair or replace free of charge, including labor, any part of this equipment which fails within **three years** of delivery of the product to the end user. Such failure must have occurred because of defect in material or workmanship and not as a result of operation of the equipment other than in accordance with the instructions given in this material. Specific exceptions include:

- Consumable items such as motor brushes, bearings, couplings and impellers. (Motor brushes typically have a life span of approximately 700 hours. This will vary with the manner in which the motor is used)

Conditions of exceptions include:

- Equipment must be returned by prepaid carriage to Standard Pump, Inc., its subsidiary or authorized distributor.
- All repairs, modifications must have been made by or with express written permission by Standard Pump, Inc., its subsidiary or authorized distributor.
- Equipment which have been abused, misused, or subject to malicious or accidental damage or electrical surge are excluded.

Warranties purporting to be on behalf of Standard Pump, Inc. made by any person, including representatives of Standard Pump, Inc, its subsidiaries, or its distributors, which do not fall within the terms of this warranty shall not be binding upon Standard Pump, Inc. unless expressly approved in writing by a Director or Manager of Standard Pump, Inc. Information for returning pumps Equipment which has been contaminated with, or exposed to, bodily fluids, toxic chemicals or any other substance hazardous to health must be decontaminated before it is returned to Standard Pump, Inc, or its distributor. A returned goods authorization number (RGA #) issued by Standard Pump, Inc., its subsidiary or authorized distributor, must be included with the returned equipment. The RGA # is required if the equipment has been used. If the equipment has been used, the fluids that have been in contact with the pump and the cleaning procedure must be specified along with a statement that the equipment has been decontaminated.

STANDARD PUMP

1540 University Drive, Auburn, Georgia 30011 USA
TOLL FREE 1-866-558-8611 • Phone 770-307-1003 • Fax 770-307-1009
e-mail: info@standardpump.com
www.standardpump.com