



THE ECONOMICAL ALTERNATIVE FOR HARD-TO-HEAT SPACES:

- Manufacturing Plants
- Warehouses
- Auto Dealerships
- Aircraft Hangars
- Loading Docks
- Fire Stations
- Commercial Garages
- Machine Shops
- Tennis Courts
- Maintenance Shops
- Farm Buildings
- Truck Service Areas

 **WARNING**
Not For Residential Use



Whether you need to heat your warehouse, machine shop, or other hard-to-heat spaces, the SunStar StarGlo ceramic infrared heater provides both the fuel efficiency of radiant heat and the installation flexibility you need . . . and all at a comfortable price.

INTRODUCING

The SunStar StarGlo™ SG Series Direct Spark Ignition

CERAMIC INFRARED HEATER

The SunStar StarGlo is the answer for spot or area heating and for total building heating needs. It is also ideal for the replacement of existing ceramic heaters, over 10 million of which have been sold in North America since the early 1950's. The SunStar StarGlo heats like the sun by transferring radiant heat energy directly into the area to be heated and creating a warm comfort zone at the floor level. This extremely efficient method of heating can result in fuel savings of between 30% and 50% when compared to forced air convection heating.

WIDE VARIETY OF APPLICATIONS

SunStar StarGlo Ceramic heaters are ideal for many heating needs. The best applications are those where doors open and close frequently and in buildings where ceiling heights are above twelve feet. These flexible SunStar infrared heaters can meet most commercial and industrial heating needs.

GENERAL FEATURES

- Capacities from 30,000 to 155,000 Btu/hr
- Dimpled tile assembly design for increased radiant efficiency
- Design certified for angle mounting up to 30 degrees
- Equipped with 100% gas shut-off safety control
- Constructed of aluminized steel for corrosion-resistance
- Aluminum reflectors designed to maximize radiant output
- Optional protective radiant screen
- Compact size for UPS shipping

TECHNICAL SPECIFICATIONS

Model	Gas Type	Input Btu/hr	No. of Burners	Minimum Mounting Height (Feet)
SG3-N	NAT	30,000	1	12
SG3-L	LP	32,000	1	12
SG4-N	NAT	40,000	1	12
SG6-N	NAT	60,000	2	13
SG6-L	LP	65,000	2	13
SG8-N	NAT	80,000	2	14
SG10-N	NAT	100,000	3	15
SG10-L	LP	100,000	3	15
SG12-N	NAT	120,000	3	16
SG13-L	LP	130,000	4	17
SG14-N	NAT	140,000	4	17
SG15-N	NAT	155,000	4	18

Gas Type	Burner Pressure (water column)	Supply Pressure (water column)	
		Minimum	Maximum
Natural Gas	6"	7"	14"
Propane Gas	10"	11"	14"

Ignition Type: Direct Spark Ignition
Supply Voltage: 115 Volt
Amp Draw: 0.40 Amp
Gas Connection: 1/2" NPT Female

MINIMUM CLEARANCES TO COMBUSTIBLES

Model	Mounted Horizontally				Mounted at 30° Angle				
	Sides	Ceiling	Below	w/ Reflector Extension	Below	w/ Reflector Extension	Front	w/ Reflector Extension	Rear
SG3 and SG4	31"	37"	73"	101"	73"	101"	37"	51"	31"
SG6 and SG8	49"	49"	99"	138"	99"	138"	49"	69"	37"
SG10 and SG12	49"	65"	129"	181"	129"	181"	61"	85"	49"
SG13, SG14 and SG15 *	49"	65"	137"	191"	137"	191"	65"	91"	49"

*Minimum mounting angle of 10 degrees. Observe all required clearances as shown. Clearances are measured from the reflector edge.

DIMENSIONS

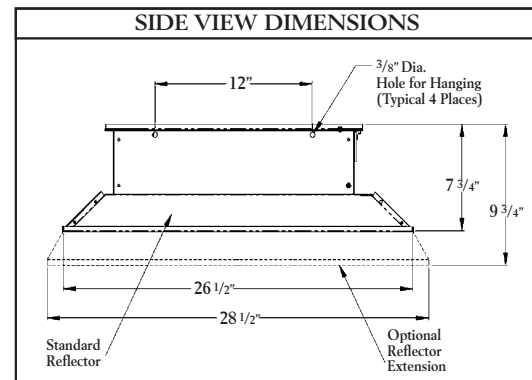
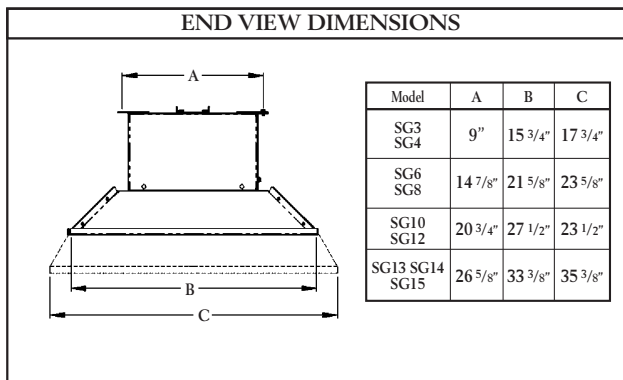

COMBUSTION AIR AND VENTILATION

Combustion air and venting requirements for all gas-fired heating equipment must be provided per the National Fuel Gas Code NFPA54 and CAN B149 or the authority having jurisdiction over the installation. Refer to Installation and Operation Instructions for further information. An indirect vented installation requires a minimum ventilation flow of 4 CFM per 1000 Btu/hr of total installed heater capacity on natural gas by either gravity or power ventilation (4.18 CFM per 1000 Btu/hr on propane). For indirect vented applications, building exhaust openings must be located above the level of the heaters and the inlet air openings must be located below the level of the heaters.

FOR YOUR SAFETY

OPERATE SUNSTAR GAS INFRARED HEATERS WITH PROPER CARE AND OBSERVE ALL SAFETY PRECAUTIONS. Installation and service must be performed by a licensed contractor. The installation must conform with local codes. In the absence of local codes, the installation must conform with the National Fuel Gas Code ANSI Z223.1 (latest edition also known as NFPA 54) or CAN B149 installation codes (latest edition). These codes are available from ANSI, 1430 Broadway, New York, NY 10018, the National Fire Protection Association, Inc., Batterymarch Park, Quincy, MA 02269 or C.S.A. 55 Scarsdale Road, Toronto, Ontario M3B 2R3 Canada.

We Make Winters Warmer
SunStar Heating Products, Inc.

306 West Tremont Avenue
 P.O. Box 36271
 Charlotte, North Carolina 28236
 Telephone (Toll Free): 1 (888) 778-6782
 Telephone (704) 372-3486
 Fax: (704) 332-5843
 Email: info@sunstarheaters.com
 www.sunstarheaters.com

SunStar Heating Products, Inc. strives to improve quality and performance on a continuing basis and reserves the right to change specifications and materials without notice.

DISTRIBUTED BY

Sales • Engineering
 "Heat and Control
 Specialists"



GORDO SALES, INC.

P.O. Box 1166 Layton, UT 84041
 Phone: 801-544-4236 Fax: 888-264-0740
<http://www.gordosales.com>

